



<http://www.electromotive.us>

# **TEC S**

## **Hardware Installation Manual**

**Electromotive Inc.**

**Copyright 2010**

# Table of Contents

|  |           |
|--|-----------|
| <b>1. Terms and Conditions</b>                                       | <b>4</b>  |
| 1.1. Electromotive Product Warranty                                  | 4         |
| 1.1.1. Warranty Replacement  | 4         |
| 1.1.2. Warranty Coverage   | 5         |
| 1.1.3. Length of Warranty  | 5         |
| 1.1.4. Who the Warranty Protects                                     | 5         |
| 1.1.5. Warranty Exclusions   | 5         |
| 1.1.6. How to Obtain Warranty Service                                | 5         |
| 1.1.7. Limitation of Implied Warranties                              | 6         |
| 1.1.8. Exclusion of Damages  | 6         |
| <b>2. Forward</b>  | <b>7</b>  |
| 2.1. TECs does not have:   | 7         |
| 2.2. Pre-Installation Checklist                                      | 8         |
| 2.3. Mounting the Main Computer and DFU                              | 8         |
| 2.4. Trigger Wheel and Sensor Installation                           | 9         |
| 2.4.1. Crankshaft Trigger Installation for 60(-2) Tooth Wheel        | 9         |
| 2.4.2. Magnetic Crank Sensor Installation                            | 10        |
| 2.4.3. Wiring the Magnetic Sensor                                    | 11        |
| 2.4.4. Verifying Trigger Wheel Timing                                | 12        |
| 2.4.5. Full Sequential Applications – Cam Synchronization            | 14        |
| 2.4.6. Trigger Voltage Adjustment for Crank and Cam Sensor Inputs    | 14        |
| 2.4.7. TDC Tooth Setup Software Adjustment Parameters                | 15        |
| <b>3. Fuel System</b>  | <b>17</b> |
| 3.1. Injector Sizing   | 17        |
| 3.2. Fuel Pump Selection   | 21        |
| 3.3. Fuel Pressure Regulator Selection                               | 21        |
| <b>4. Wiring the TECs</b>  | <b>22</b> |
| 4.1. Introduction  | 22        |
| 4.1.1. A brief word on Crimp Terminals                               | 22        |
| 4.1.2. Other tips:   | 22        |
| 4.2. TECs - Main Power Connections                                   | 23        |
| 4.2.1. Power Harness Installation                                    | 23        |
| 4.3. Wiring the DFU's  | 24        |
| 4.3.1. Pinout of the Direct Fire Unit (DFU)                          | 25        |
| 4.3.2. DFU to Spark Plugs  | 25        |
| 4.3.3. Spark Plug Wire Routing                                       | 26        |
| 4.3.4. Common Engine Setups  | 26        |
| 4.3.5. Examples of Typical Engine Setups                             | 26        |
| 4.3.6. Common Firing Orders  | 27        |
| 4.3.7. To find the TDC Event Order                                   | 27        |
| 4.3.8. Spark Plug Wire Selection                                     | 27        |
| 4.3.9. Spark Plug Selection  | 28        |
| 4.4. Fuel Injector Wiring  | 29        |
| 4.4.1. Wiring the Fuel Injectors                                     | 29        |
| 4.4.2. Injector and Firing Patterns for EVEN-FIRE 4 Cylinder Engines | 29        |
| 4.4.3. Injector and Coil Firing Patterns for 2-CYCLE Engines         | 30        |
| 4.4.4. High vs. Low Impedance Injectors                              | 30        |
| 4.4.5. Injector Firing Schemes                                       | 31        |

|           |  |           |
|-----------|--|-----------|
| 4.4.6.    | Phased Injection.....                                    | 31        |
| 4.4.7.    | True Sequential Injection .....                          | 32        |
| 4.5.      | Idle Air Control .....                                   | 32        |
| 4.5.1.    | Idle Air Control Valve .....                             | 33        |
| 4.5.2.    | Wiring a 2-wire IAC: .....                               | 33        |
| 4.5.3.    | Wiring a 3-wire IAC: .....                               | 33        |
|           | Tachometer Output.....                                   | 35        |
| 4.6.      | Fuel Pump Relay Output.....                              | 35        |
| 4.7.      | Wiring the Sensors.....                                  | 36        |
| 4.7.1.    | Manifold Air Pressure (MAP) Sensor .....                 | 36        |
| 4.7.2.    | Throttle Position Sensor .....                           | 40        |
| 4.7.3.    | Coolant Temperature Sensor.....                          | 42        |
| 4.7.4.    | Manifold Air Temperature Sensor .....                    | 43        |
| 4.7.5.    | Exhaust Gas Oxygen Sensor.....                           | 44        |
| 4.7.6.    | Wideband O2 Sensor Installation Instructions .....       | 45        |
| 4.7.7.    | Knock Sensor.....  | 45        |
| 4.8.      | General Purpose Inputs (GPI's) and Outputs (GPO's) ..... | 46        |
| 4.8.1.    | Available General Purpose Input (GPI) Functions: .....   | 46        |
| 4.8.2.    | Wiring the GPI's .....                                   | 47        |
| 4.8.3.    | GP I/O Wiring Harness Layout.....                        | 49        |
| 4.8.4.    | General Purpose Output (GPO) functions .....             | 49        |
| 4.8.5.    | Available GPO Functions .....                            | 50        |
| 4.8.6.    | Wiring the GPO's: .....                                  | 50        |
| <b>5.</b> | <b>Diagnostics .....</b>                                 | <b>52</b> |
| 5.1.      | Trouble Codes from the LED's Mounted on the TECs.....    | 53        |
| 5.2.      | Trouble Codes from the Check Engine Output.....          | 53        |
| 5.3.      | Trouble Code Descriptions.....                           | 54        |
| 5.3.1.    | Using the Trouble Codes .....                            | 55        |
| 5.3.2.    | Wiring the Check Engine Light.....                       | 55        |
| <b>6.</b> | <b>TECs ECU Specifications .....</b>                     | <b>56</b> |
| 6.1.      | OUTPUTS.....   | 56        |
| 6.1.1.    | Fuel Injector Drivers .....                              | 56        |
| 6.1.2.    | Coil Outputs .....                                       | 56        |
| 6.1.3.    | Idle Air Control (IAC) Motor.....                        | 56        |
| 6.1.4.    | General Purpose Inputs or Outputs (GP I / O's) .....     | 56        |
| 6.1.5.    | Fuel Pump Control .....                                  | 56        |
| 6.1.6.    | Tachometer Output .....                                  | 56        |
| 6.1.7.    | Check Engine Light Output .....                          | 56        |
| 6.1.8.    | ECU Diagnostic LED.....                                  | 57        |
| 6.2.      | INPUTS .....   | 57        |
| 6.2.1.    | General Purpose Inputs or Outputs (GP I / O's) .....     | 57        |
| 6.2.2.    | Engine Sensor Inputs.....                                | 57        |
| 6.2.3.    | Angle Based Timing Control .....                         | 57        |
| 6.2.4.    | Feedback Charging Control .....                          | 57        |
| 6.3.      | Tuning Features.....                                     | 58        |
| 6.3.1.    | Ignition Timing Map.....                                 | 58        |
| 6.3.2.    | Fuel Map .....   | 58        |
| 6.3.3.    | Load Sensing – Three Options .....                       | 58        |
| 6.3.4.    | Rev Limiters .....                                       | 58        |
| 6.3.5.    | On-Fly Tuning .....                                      | 58        |
| 6.3.6.    | Compensation Features.....                               | 58        |
| 6.4.      | Supported Engine Management Configurations .....         | 58        |
| 6.4.1.    | 4-Stroke.....  | 58        |
| 6.4.2.    | 2-Stroke.....  | 58        |

|           |  |           |
|-----------|--|-----------|
| 6.5.      | Data logging Features.....                           | 59        |
| 6.5.1.    | Laptop Data logging.....                             | 59        |
| 6.6.      | Physical Dimensions.....                             | 59        |
| 6.7.      | Environmental Considerations.....                    | 59        |
| 6.8.      | PC Requirements.....                                 | 59        |
| 6.8.1.    | Computer.....  | 59        |
| 6.8.2.    | Data Drives.....                                     | 59        |
| 6.8.3.    | Communications.....                                  | 59        |
| <b>7.</b> | <b>Electromotive Trigger Wheel Availability.....</b> | <b>59</b> |
| <b>8.</b> | <b>Calibration Software.....</b>                     | <b>61</b> |
| 8.1.      | Software Coding Information.....                     | 61        |
| 8.2.      | Firmware Coding Information.....                     | 61        |
| 8.3.      | Firmware Upgrade Procedure.....                      | 61        |
| <b>9.</b> | <b>TECs Wiring.....</b>                              | <b>63</b> |
| 9.1.      | Pinout Information.....                              | 63        |
| 9.2.      | Connector Pin Locations.....                         | 63        |
| 9.3.      | TECs Signal Wire Harness.....                        | 64        |
| 9.4.      | TECs 4 Cylinder Power Wiring.....                    | 65        |

## 1. Terms and Conditions

### 1.1. Electromotive Product Warranty

Only products Manufactured by Electromotive are covered by Electromotive's limited warranty for a period of one-year from date of shipment by Electromotive.

Products not manufactured by Electromotive are expressly excluded from any consideration under these terms – for information regarding products not manufactured by Electromotive you must contact the specific product's manufacturer.

Whenever possible, Electromotive attempts to replace defective products rather than repair them. Replacement puts the "Customer First" and offers many benefits over repair; the greatest benefit being the timeliness of the replacement process. However, in some cases, replacement with a 'like new' refurbished product is not possible, and a warranty repair situation occurs. In these situations, Electromotive strives to keep our repair times to a minimum (on average 2 to 3 business days upon receipt - excluding the necessary shipping time). Customers should follow the appropriate steps outlined below to initiate a warranty replacement or repair.

#### 1.1.1. Warranty Replacement

Contact Electromotive Technical Support at 1-703-331-0100 9am to 5pm Eastern Time. The customer must have the serial number and original proof-of-purchase available. Electromotive's Technical Support staff will attempt to help you correct any minor issues that might be causing the problem. If we are unable to fix the issue to your satisfaction, a return merchandise authorization (RMA) number will be issued. Under our Warranty program, Electromotive will typically ship the customer a replacement unit on the same day the defective product arrives.

The replacement product will assume the remainder of your original product's warranty or 90 days, whichever is greater.

### **1.1.2. Warranty Coverage**

Electromotive warrants its products to be free from defects in material and workmanship during the warranty period. If a product proves to be defective in material or workmanship during the warranty period, Electromotive will, at its sole option, repair or replace the product with a similar product. Replacement product or parts may include remanufactured or refurbished parts or components.

### **1.1.3. Length of Warranty**

Electromotive products are warranted for one (1) year parts and one (1) year labor. Warranty begins upon date of shipment from Electromotive.

### **1.1.4. Who the Warranty Protects**

This warranty is valid only for the purchaser from Electromotive.

### **1.1.5. Warranty Exclusions**

Any product, on which the serial number has been defaced, modified or removed.

Damage, deterioration or malfunction resulting from:

Accident, misuse, neglect, fire, water, lightning, or other acts of nature, unauthorized product modification, or failure to follow instructions supplied with the product

Repair or attempted repair by anyone not authorized by Electromotive.

Any damage of the product due to shipment.

Removal or installation of the product

Causes external to the product, such as electric power fluctuations or failure.

Use of supplies or parts not meeting Electromotive's specifications

Any other cause, which does not relate to a product defect

Removal, installation, and set-up service charges

Shipping Charges.

Any warranty of merchantability, express or implied, is excluded except as otherwise set forth herein.

There are no warranties that extend beyond the description on the face of this document.

There are no warranties of fitness for a particular purpose except as stated on the face of this "Electromotive Product Warranty".

Any and all oral warranties are excluded and will not be honored.

Consequential damages will not be covered by this warranty.

### **1.1.6. How to Obtain Warranty Service**

For information on warranty service, contact your Electromotive Value Added Dealer or call Electromotive Technical Support at 1-703-331-0100 from 9am to 5pm Eastern Time Monday through Friday - e-mail [support@electromotive-inc.com]. To obtain warranty service, you will be required to provide:

Original dated sales receipt

Your name

Your address

The serial number of the product

A description of the problem

Contact information (daytime phone number or email address)

Take or ship the product in the original or a suitable replacement container to:

Electromotive, Inc.  
9131 Centreville Road  
Manassas VA 20110

### **1.1.7. Limitation of Implied Warranties**

THERE ARE NO WARRANTIES, EXPRESS OR IMPLIED, WHICH EXTEND BEYOND THE DESCRIPTION CONTAINED HEREIN INCLUDING THE IMPLIED WARRANTY OF MERCHANTABILITY AND FITNESS FOR A PARTICULAR PURPOSE.

### **1.1.8. Exclusion of Damages**

ELECTROMOTIVE'S LIABILITY IS LIMITED TO THE COST OF REPAIR OR REPLACEMENT OF THE PRODUCT. ELECTROMOTIVE SHALL NOT BE LIABLE FOR:  
DAMAGE TO OTHER PROPERTY CAUSED BY ANY DEFECTS IN THE PRODUCT, DAMAGES BASED UPON INCONVENIENCE, LOSS OF USE OF THE PRODUCT, LOSS OF TIME, LOSS OF PROFITS, LOSS OF BUSINESS opportunity, LOSS OF GOODWILL, INTERFERENCE WITH BUSINESS RELATIONSHIPS, OR OTHER COMMERCIAL LOSS, EVEN IF ADVISED OF THEIR POSSIBILITY OF SUCH DAMAGES.  
ANY OTHER DAMAGES, WHETHER INCIDENTAL, CONSEQUENTIAL OR OTHERWISE.  
ANY CLAIM AGAINST THE CUSTOMER BY ANY OTHER PARTY  
SHIPPING CHARGES.

## 2. Forward

The **TECs** Total Engine Control system is a custom designed engine management systems for use with up to 4 cylinder engines. The heart of the TEC series of engine management systems has always been a high-resolution ignition, which offers incredibly precise ignition timing even at the highest acceleration rates. The **TECs** continues this tradition; only what was once done with an analog ignition circuit is now done with a high-speed microprocessor. Direct Fire Units (DFU's) with twin-tower coils are available from Electromotive in 2 coil versions. Single tower coils are available as well. These DFU's are completely weather proof, and feature sealed electrical connectors. Additionally, the DFU's are impedance matched for optimum performance with our **TECs**.

The **TECs** has up to four dedicated fuel channels for high impedance injectors. Each output can drive up to two 12 ohm or greater injectors. Do not use low impedance "peak and hold" type injectors on the **TECs**. Sequential operation is available through the use of a cam position sensor but sequential operation reduces the number of General Purpose Outputs.

There are up to five user-definable, general-purpose inputs / outputs (GP I/O's) included with the **TECs** to make your high-tech engine setup a snap. The GP I/O's can be used to control anything from wastegates for turbo setups to simple electric radiator or intercooler fans.

One of the GPI's is a vehicle speed input, which can process data from wheel speed sensor or similar device. The other GPI's are analog inputs only, and do not feature frequency-based capabilities. These channels can perform fuel trims, timing trims, and many other functions.

Besides the GP I/O's, several functions are built-in to the **TECs** that are quite useful on most applications. The following outputs are standard on the **TECs**:

- Tachometer (configurable to drive most modern tachs)
- Fuel Pump Relay Ground (activated at appropriate times by the **TECs**)
- Idle Speed Motor control (2-wire style only)

The **TECs** uses the following inputs to perform engine management:

- Crank Trigger (60-2)
- Cam Trigger (optional)
- Manifold Absolute Pressure or Mass Air Flow Sensor
- Coolant Temperature Sensor
- Manifold Air Temperature Sensor
- Throttle Position Sensor
- Knock Sensor (optional)
- Exhaust Gas Oxygen Sensor (O<sub>2</sub> sensor)

### 2.1. **TECs does not have:**

- Low Impedance, peak and hold injector outputs
- A dedicated check engine lamp output
- Internal data logging
- Staged Injection table
- The same 23 pin out as an Electromotive XDI or XD12.

## 2.2. Pre-Installation Checklist

To perform a complete **TECs** installation, the following items are required:

### **TECs** Computer

1. DFU Ignition Coil pack
2. Resistor Core Spark Plug Wires (see notes on Spark Plug Wires)
3. **TECs** Wiring Harness w/ Power Harness
4. Windows-based PC-type Computer (see notes on Computer Requirements)
5. Serial Connector Cable (DB9) for PC and a USB to Serial Converter
6. Crank Position Sensor (Magnetic Sensor) and bracket
7. 60 (-2) Tooth Crank Trigger Wheel
8. Coolant Temperature Sensor (CLT)
9. Manifold Air Pressure Sensor (MAP)
10. Throttle Position Sensor (TPS)
11. Fuel Rail(s) and Fuel Pressure Regulator
12. High Pressure Electric Fuel Pump
13. High Resistance Fuel Injectors
14. Fuel Injector Wiring Harness
15. Throttle Body
16. Wire Terminal Crimping Tool (available from Electromotive)
17. Qty. 4 ¼" Bolts for DFU & Qty. 4 #10 screws for the **TECs**
18. WINTEC4 Software Guide

Optional:

Manifold Air Temperature Sensor (MAT)  
Exhaust Gas Oxygen Sensor (EGO)  
Idle Air Control Motor (IAC)  
Knock Sensor (KNK)

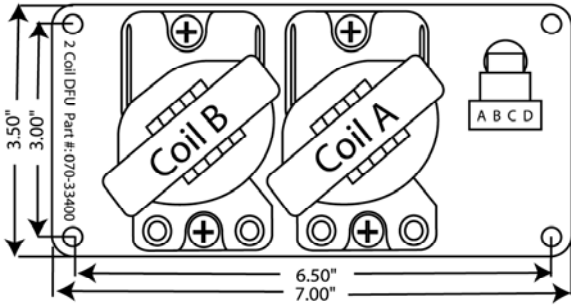
## 2.3. Mounting the Main Computer and DFU

For utmost reliability, install the **TECs** computer where temperatures will not exceed 150°F (65°C). It is recommended that the **TECs** computer be installed in the passenger compartment of the vehicle where it will not be exposed to the elements. A good location is in the kick panel of a vehicle originally equipped with a factory ECU. If the **TECs** must be mounted in an area that is partially exposed to the elements, there should not be a problem; the circuit board is completely sealed for harsh environment installations. A well-vented area is recommended. It should be noted that the **TECs** might get hot under prolonged high-rpm operation. As long as air is moving around the ECU, there is no risk of damage to the **TECs**. Secure the **TECs** ECU with four #10 screws. The wiring harness should be passed through the firewall using a suitable grommet to avoid chafing.

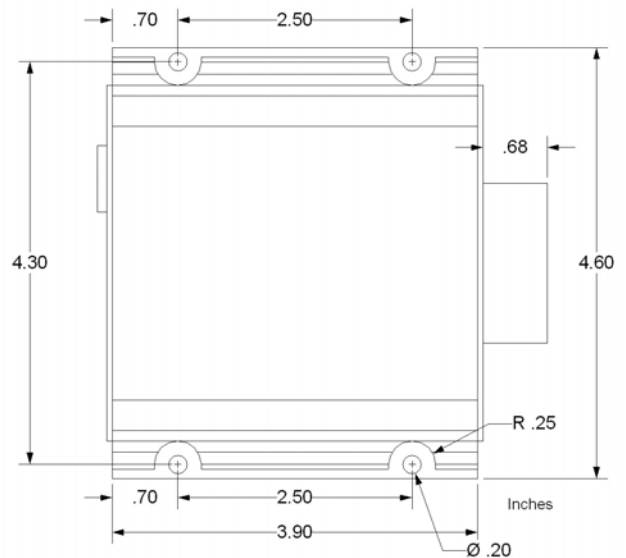
The DFU can be placed nearly anywhere under the hood of the vehicle where the temperatures are below 250°F (120°C). Since they are entirely sealed, exposure to the elements is not an issue. The DFU Ground Wire **MUST** be installed to vehicle ground.

It is recommended that the ECU and DFU be separated by at least six inches for the purpose of reducing electrical noise in the ECU.





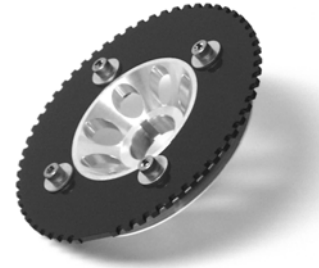
**2-Coil DFU Dimensions**



TECs ECU Dimensions (bolt pattern is 4.3" x 2.5")

## 2.4. Trigger Wheel and Sensor Installation

The foundation of the **TECs** ultra-high resolution ignition is the 60(-2) tooth trigger wheel. The trigger wheel is designed to give uncompromising timing accuracy at the highest engine acceleration rates. As such, Electromotive does not support other triggering systems, particularly those of the “flying magnet” variety. These systems can lead to vastly inaccurate spark timing, and can contribute to engine damage. For most applications, the 60(-2) tooth trigger wheel is mounted on the crankshaft damper or pulley. Some applications may warrant the use of a camshaft- or distributor-mounted trigger wheel. With this setup, a 120(-4) tooth trigger wheel is necessary, since the camshaft turns at half the speed of the crank.



### 2.4.1. Crankshaft Trigger Installation for 60(-2) Tooth Wheel

For a crankshaft-mounted trigger wheel setup, an appropriate place must be found to mount the wheel and trigger. Typically, the easiest place to mount a trigger wheel is on the harmonic damper or pulley. If it is mounted on a damper, it should be mounted on the inner hub rather than the outer dampening ring. The damper/pulley should be keyed to the crankshaft so that it cannot spin on the crankshaft, as this would cause an ignition timing error. When using a damper that has bolt-on pulleys, the trigger wheel can usually be mounted between the pulleys and the damper. However, the accessory pulleys will need to be shimmed out by 1/8" (the thickness of the trigger wheel). A variety of application-specific trigger wheels are available. See **Appendix II** for a listing of applications. Universal trigger wheels are also available in a variety of sizes, and are listed in **Appendix II** as well. Electromotive can custom-make trigger wheels in nearly any configuration for a one-time tooling fee.

To choose the proper size trigger wheel, find the diameter of the pulley or damper on which the wheel is to be mounted. The trigger wheel diameter should be about 1/2" larger than this diameter. It should also be noted that the trigger wheel should be at least 1/4" from any moving magnetic pieces, such as bolts or other fasteners, to avoid interference and false triggering. It is important that the trigger wheel be perfectly concentric with the crankshaft centerline. To achieve concentricity, a shallow cut can be machined in the

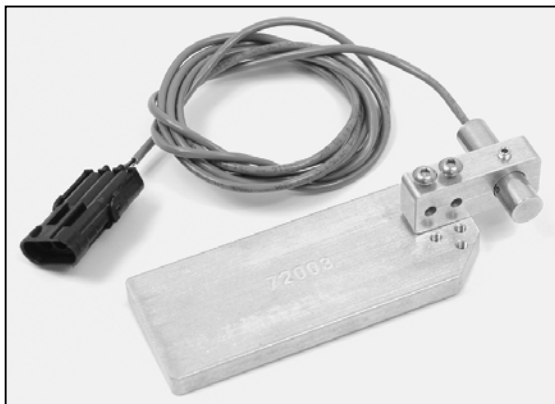
front or rear face of the damper to create a centering ledge, and a hole can be created in the trigger wheel to match the ledge diameter. The trigger wheel can then be drilled to bolt it to the damper. See **Table** below to determine the tolerances that must be maintained when mounting the trigger wheel. These tolerances may require the use of a lathe to true the trigger wheel with the crankshaft centerline, which can be accomplished by putting the entire damper/trigger wheel assembly on the lathe. Note that the maximum out-of-round is the distance between the lowest and highest teeth and the crank sensor. That is, if a feeler gauge is used between the sensor and the wheel to measure the out-of-round, the reading between the lowest and highest teeth should not exceed the guidelines in the table.

#### 1.1.1.1. Crank Trigger Specifications

| Trigger Wheel Size | Air Gap    | Maximum Out-of-Round |
|--------------------|------------|----------------------|
| 2.5"               | 0.025" max | 0.002"               |
| 3.5"               | 0.035" max | 0.003"               |
| 5"                 | 0.050" max | 0.005"               |
| 6"                 | 0.060" max | 0.006"               |
| 7.25"              | 0.070" max | 0.007"               |
| 8.25"              | 0.080" max | 0.008"               |

### 2.4.2. Magnetic Crank Sensor Installation

When installing the magnetic sensor, an appropriate bracket must be made to aim the sensor at the trigger wheel. A good starting point for a magnetic sensor bracket is Electromotive part number 210-72003, which is our universal sensor bracket. If this part is not used as a starting point, a custom bracket can easily be made. **The most important things to remember when fabricating a bracket are that it should be bolted directly to the engine block, away from rotating steel or magnetic pieces, and should be nonferrous (not attracted to magnets).** This will keep the sensor and trigger wheel vibrating together so the gap between the two always stays the same. Variations in sensor gap may cause erratic timing or false triggering of the ignition. (This is the reason for not mounting the trigger wheel to the outer ring of a harmonic damper.) As such, any custom magnetic sensor bracket should be very rigid. The sensor can be secured with either a set screw or a clamping arrangement, as long as the 1/2" sensor is utilized (part number 250-72218). If the smaller 3/8" sensor is utilized, a clamping arrangement should be employed rather than a setscrew, as the setscrews may crush the sensor. See **Table below** for the appropriate magnetic sensor/trigger wheel combinations.



Universal Crank Sensor Bracket

trailing edge of the 10<sup>th</sup> tooth, the timing will be retarded by six degrees. In the event that the sensor is not aligned correctly, the WinTec4 software can be used to compensate by manipulating the Tooth Offset Parameter, as outlined in software manual.

Once a magnetic sensor and trigger wheel are installed, they must be aligned such that the **TECs** computer knows where to locate Top Dead Center of the #1 cylinder (referred to as TDC #1). **Correct alignment necessitates that the center of the sensor must be aligned with the trailing edge of the 11<sup>th</sup> tooth after the two missing teeth when the engine is at TDC #1 (see the drawing at the end of this section).** Aligning the magnetic sensor with anything other than the 11<sup>th</sup> tooth will cause an ignition timing retard or advance, depending on the direction of the misalignment. Each tooth represents six degrees, so if the sensor is aligned with the trailing edge of the 12<sup>th</sup> tooth, the timing will be advanced by six degrees. Conversely, if the sensor is aligned with the

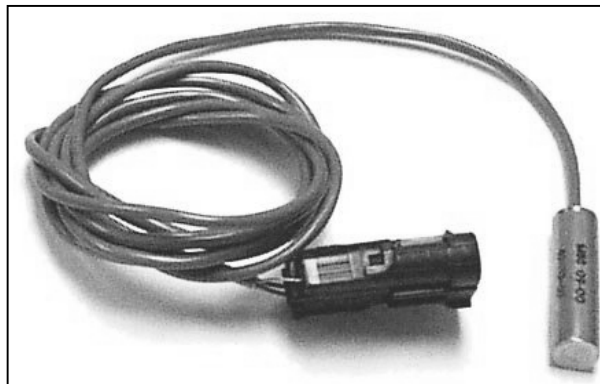
**IMPORTANT NOTE:**

Make sure that the Mag. Sensor harness is NOT routed near battery cables or other high current leads or devices such as cooling fans, starter or alternator. Coil wires, injector leads also should be avoided.

Note: use a clamping arrangement for securing 3/8" sensors, rather than a setscrew. The 1/2" sensors can be secured with any clamping method.

**1.1.1.2. Magnetic crank sensor selection**

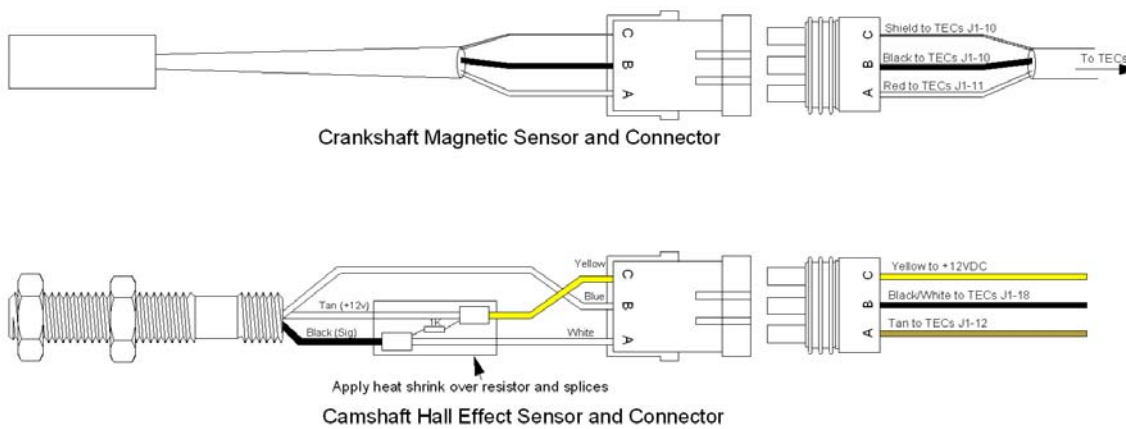
|  | 3/8" Diameter Chisel Point Sensor<br>PN: 250-72212 | 1/2" Diameter Flat Tip Sensor<br>PN: 255-72218 |
|--|--|--|
| All 120 (-4) Tooth                       | X  |  |
| 2-3/8" & 2-1/2" 60 (-2) Tooth            | X  |  |
| 3-1/2" 60 (-2) Tooth (below 6000rpm)     | X  | X  |
| 3-1/2" 60 (-2) Tooth (Above 6000rpm)     | X  | X  |
| Greater than 3-1/2" 60 (-2) Tooth wheels | X  | X  |



**2.4.3. Wiring the Magnetic Sensor**

The crank sensor has three wires. The red wire is the signal from the sensor, the black wire is the signal ground, and the bare wire is the shield. The harness has provisions for both a crank and a cam sensor.

**The crank sensor cable must be used for all 60 (-2) or 120 (-4) tooth trigger wheel inputs.** The cam sensor cable should only be used for the "sync" pulse from the cam-mounted trigger wheel on sequential applications.

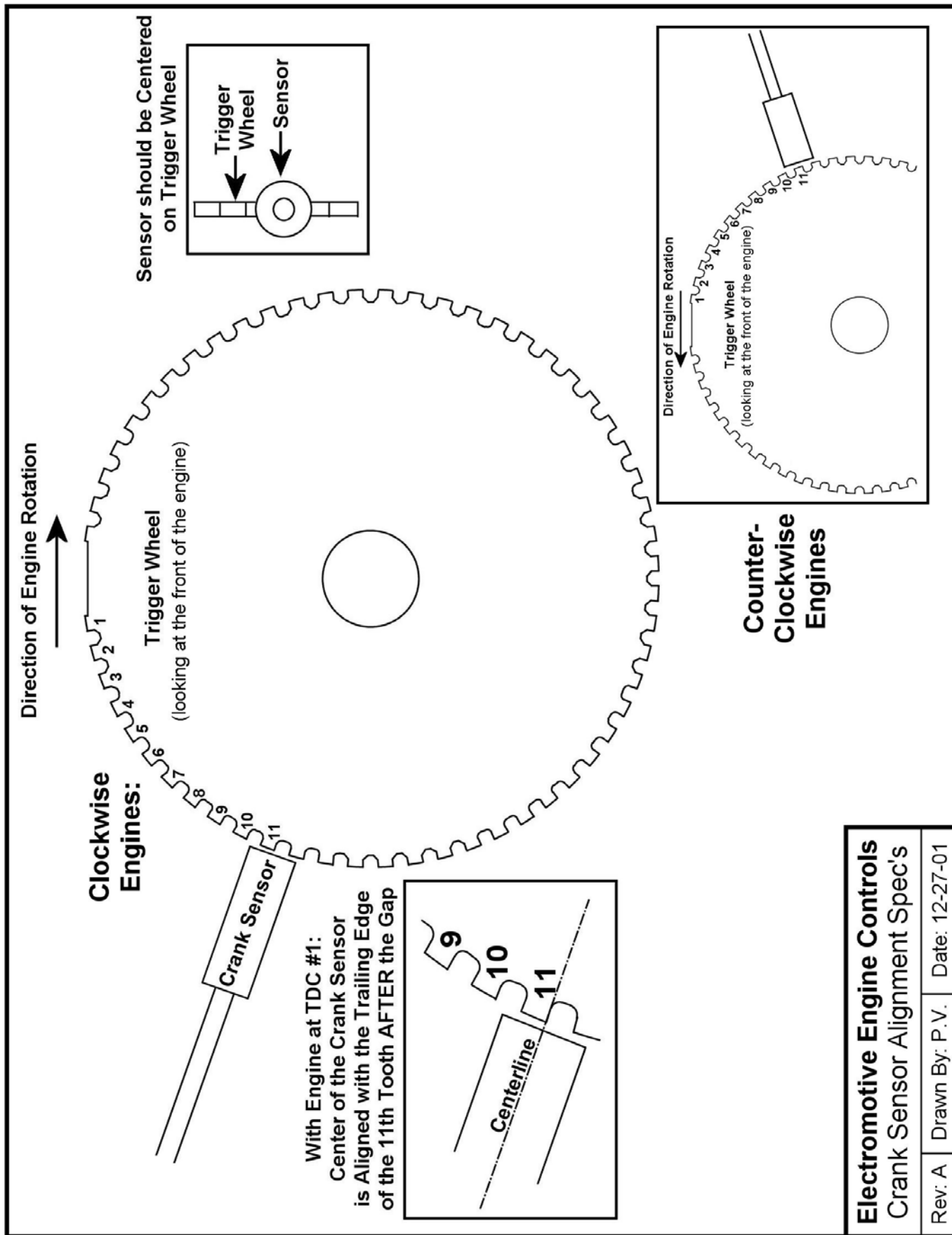


**Figure:** Wiring layout for crank J1-11 and cam J1-12 sensor inputs. Note that the Cam Sensor is only used on full sequential applications. It is NOT used on applications using the 120(-4) tooth cam trigger wheel with no crank trigger.

#### 2.4.4. Verifying Trigger Wheel Timing

The most important step in the trigger wheel installation process is to check the ignition advance with a timing light. A timing indicator (pointer) should be attached to the engine block, and it should point at a line on the crankshaft pulley or trigger wheel when the engine is at TDC #1. When running the engine, verify that the timing value read by the timing light corresponds to the timing value in the software's engine monitor screen.

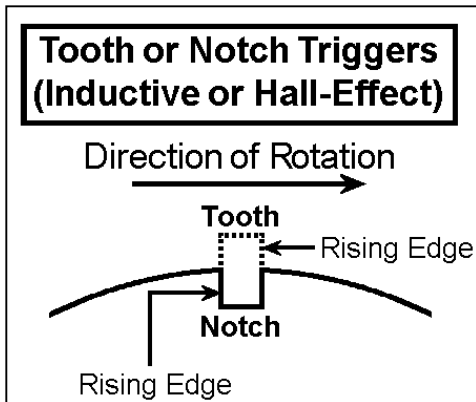
Use of a good-quality inductive timing light is recommended. DO NOT use a timing light that goes between the spark plug and spark plug wire with a clamp probe. Dial-Back inductive timing lights can be used, but will need to be dialed to DOUBLE the actual desired timing value due to the waste-spark firing of the DFU coils. They are fooled into thinking that the timing is twice as advanced as it actually is.



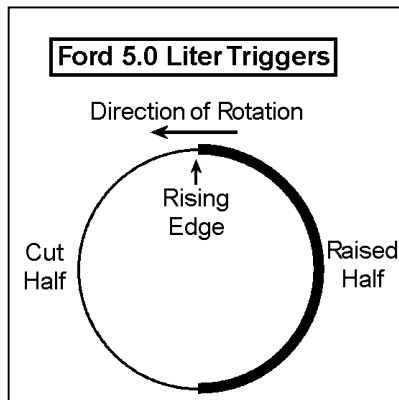
## 2.4.5. Full Sequential Applications – Cam Synchronization

When full sequential fuel operation is desired, a once-per-engine-cycle synchronization, or “sync,” pulse must be received by the ECU. Typically, the sync pulse is generated by the installation of a 1-notch (or 1-tooth) trigger wheel onto the camshaft. A special Electromotive Hall Effect sensor can then be used to obtain the reading from this trigger wheel. A Magnetic sensor could also be used as a triggering method instead of a Hall Effect sensor setup but it may be more sensitive to electrical interference. With either method, the tooth must pass by the magnetic sensor between 180° and 6° before TDC Compression (not exhaust) of the number one cylinder. See **Figure Below** for installation details.

The TECs will only trigger off a rising edge during the synchronization period (between 180° and 6° BTDC compression). A rising edge occurs when the air gap on the cam trigger wheel gets larger. See Figures A.4. 6 and 7 for representative examples and different cam trigger wheel designs, and their rising edge location.



**Figure:** Tooth/Notch Triggers



**Figure:** Ford “Half-Moon” Trigger

Most types of sensors are compatible with the **TECs** sync pulse requirement. This would include most Hall effect, flying magnet, and retractor sensors. As long as the sensor outputs a rising voltage to the **TECs** between 180° and 6° before TDC compression for the number one cylinder, it should work perfectly.

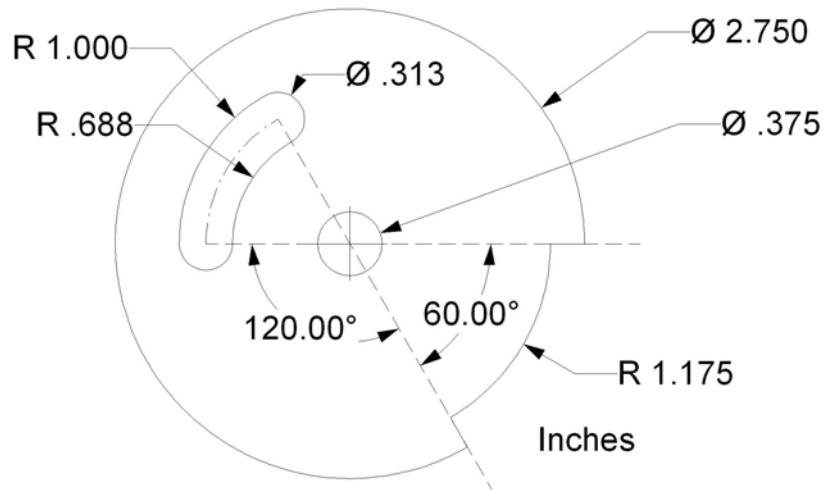
Terminal J1-12 on the ECU is used for cam sync inputs. If using a Hall effect or other sensor type that is powered by +12Volts, be sure that the output signal from the sensor is going into terminal J1-12. If using a magnetic sensor with a custom steel trigger wheel, we recommend using our magnetic sensors. The red wire from the sensor should go to terminal J1-12. When using a Magnetic Sensor for a CAM pickup it is necessary to remove the “CAM” jumper that is found in the **TECs**. Keep in mind that when adapting an OEM cam trigger setup to a **TECs**, the wheel may need to be rotated to place the rising edge in the appropriate degree window for the **TECs**.

## 2.4.6. Trigger Voltage Adjustment for Crank and Cam Sensor Inputs

Two different trigger voltages are available in the TECs for different types of sensors. They are:

| Sensor Type     | Trigger Voltage | Jumper Setting |
|-----------------|-----------------|----------------|
| Hall Effect     | 2.5 Volts       | On             |
| Magnetic Sensor | 0.0 Volts       | Off            |

**Figure:** Proper cam trigger installation. This cam trigger occurs approx. 90° BTDC Compression on the #1 cylinder (as measured at the crank). Note the 87 degree (as measured on the cam wheel) “window” in which the rising edge must occur.



Sample Camshaft Sensor Wheel

To setup the right voltage value, remove the rear end plate on the TECs. Just to the right of the Serial Connector are pins that have either have or do not have little black plastic blocks on them. The plastic blocks are the jumpers. Install a jumper or remove it for each Crank or Cam input for what you have planned on the engine. The pins are labeled “CRANK” and “CAM”

### 2.4.7. TDC Tooth Setup Software Adjustment Parameters

The WinTec4 software features a TDC setup parameter that allows users to manipulate the TDC point for the trigger wheel.

Some applications may require more “mechanical timing” to compensate for large, high-overlap cams. Assuming the crank sensor is aligned with the 11<sup>th</sup> tooth at TDC, this can be done by entering a value for the “Change DFU Trigger Wheel TDC” that is LESS than 11. Each tooth less than 11 represents 6 degrees of advance that is added to the Ignition Advance Table.

Some applications may require less “mechanical timing” (some rotary users may wish to do this). Assuming the crank sensor is aligned with the 11<sup>th</sup> tooth at TDC, this can be done by entering a value for the “Change DFU “A” Trigger Wheel TDC” that is MORE than 11. Each tooth more that 11 represents 6 degrees of retard that is subtracted from the Ignition Advance Table.

The following pages outline the various situations that can be addressed through the TDC software parameters.

#### Situation A

Problem:

Incorrect trigger wheel alignment results in undesired mechanical timing.

Solution:

With the engine at TDC #1, find the trigger wheel tooth that is aligned with the crank sensor. Enter the number of this tooth into the TDC Tooth Alignment Parameter. The timing will be shifted to make the Ignition Advance Table accurate.

Method:

The software will automatically RETARD the timing when a number GREATER THAN 11 is entered into the TDC Tooth Alignment Parameter. The timing will be automatically ADVANCED when a number LESS THAN 11 is entered.

## Situation B

### Problem:

The engine needs less mechanical advance, and the crank sensor is aligned with the 11<sup>th</sup> tooth.

### Solution:

Enter in the number "12" to the TDC Tooth Alignment Parameter. The timing values will be automatically RETARDED by 6 degrees. The Ignition Advance Table values will now be incorrect (the displayed values will be 6 degrees higher than the actual advance).

## Situation C

### Problem:

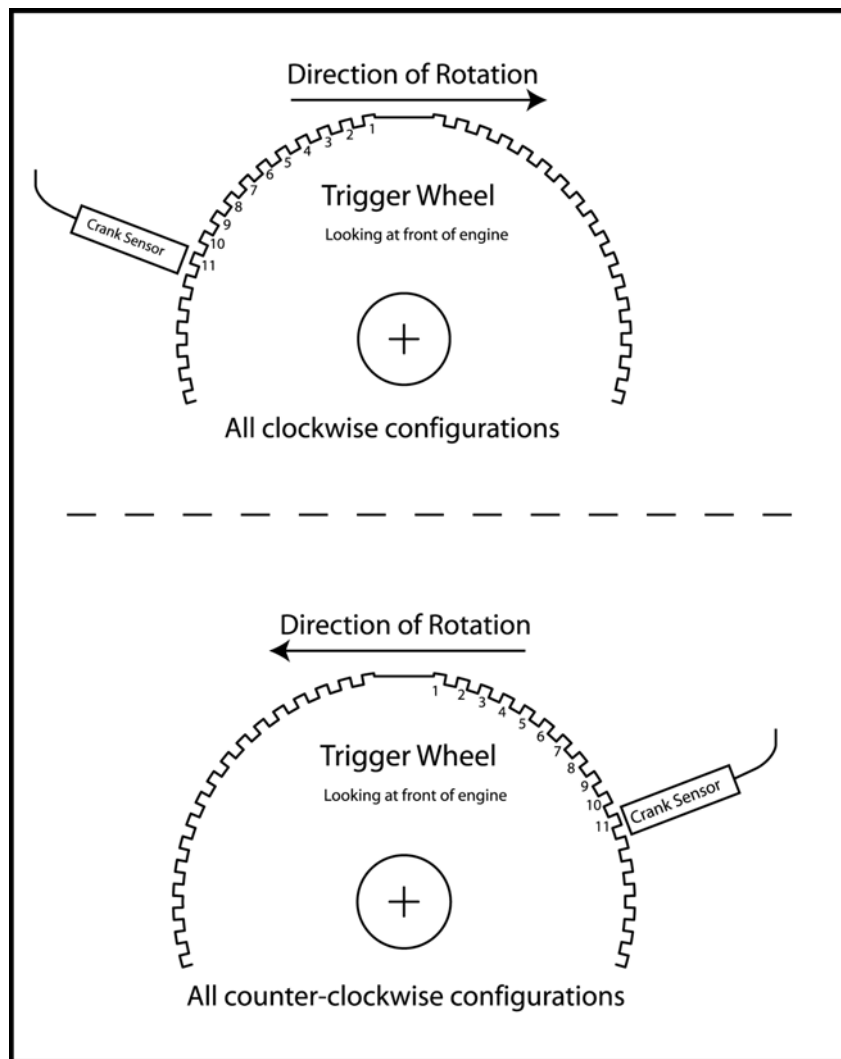
The engine needs more mechanical advance, and the crank sensor is aligned with the 12<sup>th</sup> tooth instead of the 11<sup>th</sup>.

### Solution:

Enter in the number "11" to the TDC Tooth Alignment Parameter. The timing values will be automatically ADVANCED by 6 degrees. The Ignition Advance Table values will now be incorrect (the displayed values will be 6 degrees lower than the actual advance).

### Note:

In the past, aligning the sensor with the 12<sup>th</sup> tooth would advance the mechanical timing by 6 degrees.



**Figure:** TDC tooth for two possible scenarios.



In a normal scenario, not considering software manipulation, aligning the magnetic sensor with anything other than the 11<sup>th</sup> tooth will cause an ignition timing retard or advance, depending on the direction of the misalignment. Each tooth represents six degrees, so if the sensor is aligned with the trailing edge of the 12<sup>th</sup> tooth, the timing will be advanced by six degrees. Conversely, if the sensor is aligned with the trailing edge of the 10<sup>th</sup> tooth, the timing will be retarded by six degrees. If some ignition advance is required for easier starting (high compression/radical cam timing engines, for example), aligning the sensor with the 12<sup>th</sup> or 13<sup>th</sup> tooth will yield 6° or 12° (respectively) of advance during cranking. Also check that the sensor is centered over the edge of the wheel.

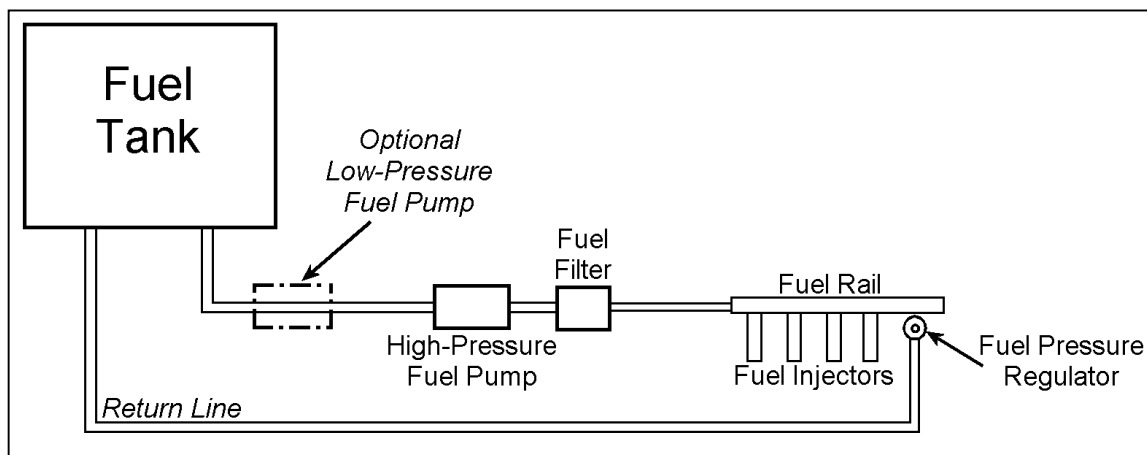
### 3. Fuel System

A poorly designed fuel system will result in fuel delivery problems. There are a few common mistakes that are easy to avoid by following the recommendations in this section. See **Figure Below** for a typical fuel system layout.

If the high-pressure fuel pump is mounted ABOVE the fuel level in the gas tank, a low-pressure transfer pump should be installed before the high-pressure pump. A fuel pump designed for a carbureted application should be used for the transfer pump (do not use a TBI-style pump as a transfer pump). High-pressure pumps often burn out when required to draw suction. Most low-pressure pumps are designed to be able to pull a good amount of suction without failure. Use a fuel pump designed for a carburetor when selecting a low-pressure pump.

Fuel pumps that are internal to the gas tank will often last longer than external pumps. However, care should be taken to ensure that an in-tank pump is capable of flowing enough fuel for a given application. Reference the vacuum port on the fuel pressure regulator to intake manifold vacuum/pressure. On highly boosted engines, the hose should be secured with a zip tie or wire.

The fuel pump power should be fused. For proper fuse selection, it is necessary to know the amperage draw of the fuel pump. Typically, a 10amp fuse will be adequate for most applications.



**Figure:** Fuel system plumbing.

#### 3.1. Injector Sizing

The most important component of the fuel system is the fuel injector. Injectors must be flow matched to maintain a consistent fuel supply for all cylinders. Cylinder-to-cylinder fuel variations can lead to poor performance, increased fuel consumption, or even catastrophic detonation. Additionally, the size of the injector plays a large role in tuning a vehicle. Injector sizes (flow rates) are generally given in either pounds-per-hour (lbs/hr) or cubic centimeters per minute (cc/min). (Note that 1 lb/hr = 10.5 cc/min.)

These ratings are either made by the injector manufacturer or by an aftermarket injector modifier. In either case, the importance of the pressure at which the flow rating was obtained must be realized. As an example, an injector that was rated at 40 lbs/hr at 43.5psi pressure will NOT supply 40 lbs/hr when operated at 30psi...it will flow more like 34 lbs/hr.

For an injector to be "sized" properly for an engine, a few things must be taken into consideration:

Number of Cylinders

Number of Injectors

Engine Horsepower

Peak RPM

Brake Specific Fuel Consumption (BSFC)

Injector Recovery Time (IRT)

The Brake Specific Fuel Consumption (BSFC) is a scaling factor used for fuel flow calculations. Its units are pounds-per-hour per horsepower (lbs/hr per HP). Typically, gasoline engines run BSFC's between 0.40 and 0.60. Alcohol engines generally run BSFC's between 0.80 and 1.20. A lower BSFC value indicates a more efficient engine. The original 4-cylinder BMW M3 engine has a BSFC of around 0.43. A turbo engine will normally have a BSFC above 0.5.

Example:

Engine Horsepower = 300

BSFC = 0.50

$300 \text{ HP} \times 0.50 \text{ lbs-per-hr/HP} = 150 \text{ lb/hr}$

This engine would require a total of **150 lbs/hr** of fuel flow.

The Injector Recovery Time is the time that it takes for an injector to open once it receives a voltage signal. Typically, a low-impedance injector will have an IRT of around 1.3 milliseconds. A high impedance injector will generally have an IRT of 1.5 ms. this number determines two things:

1. The minimum time that the injector can be pulsed
2. The maximum duty cycle

If an injector is given a pulse width that is shorter than its IRT, it will flutter. This will cause erratic fuel metering, and ultimately horrible engine performance. This scenario sometimes occurs at idle on high-revving, high-horsepower engines with large injectors. If the IRT is not accounted for in high-rpm situations, the duty cycle will be too great, and the injector will flutter. This scenario occurs on engines with injectors that are too small.

To properly size an injector, the following sequence of equations should be followed:

$\text{HP} \times \text{BSFC} = \text{Total Fuel Flow Requirement for the Engine (TFFR)}$

$\text{TFFR} \div (\# \text{ of Injectors}) = \text{Uncorrected Injector Size (UIS)}$

$60000 \div (\text{Peak RPM}) = \text{Available Injection Time (ms) per Revolution (AIT)}$

$(\text{AIT} - \text{Injector Recovery Time in ms}) \div \text{AIT} = \text{Maximum Duty Cycle (MDC)}$

$\text{UIS} \div \text{MDC} = \text{Required Injector Size}$

The above calculation assumes an injection scenario in which an injector is held open for a maximum of one engine revolution (typical phase sequential setup). For other firing options in which the injector is held open for 2 revolutions, multiply AIT by 2.

Example:

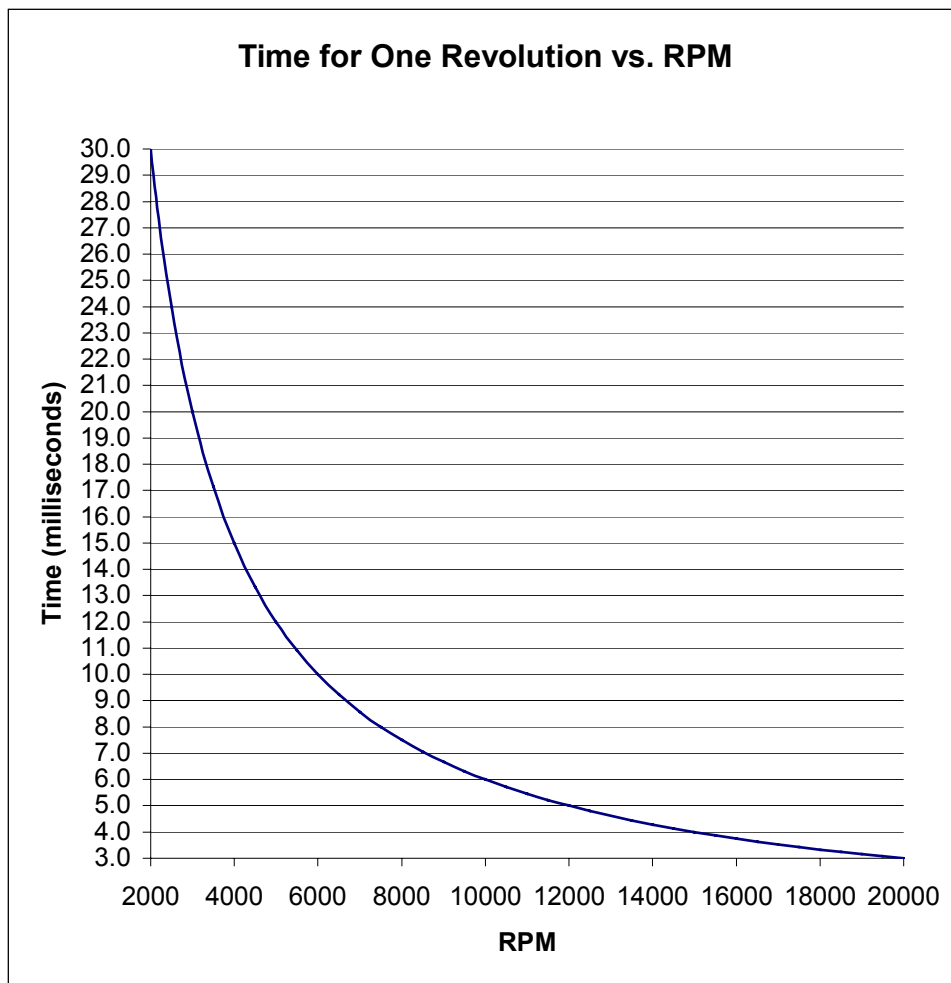
Engine Setup:            250HP 4-cylinder with 4 injectors  
                                 Phase Sequential Injector Firing  
                                 High Impedance Injectors (1.5ms IRT)  
                                 Peak HP occurs at 6500 rpm

BSFC = 0.5

Calculations:

$TFFR = 500 \times 0.5 = 250 \text{ lb/hr}$   
 $UIS = 250 \div 8 = 31.25 \text{ lb/hr}$   
 $AIT = 60000 \div 6500 = 9.231 \text{ ms}$   
 $MDC = (9.231 - 1.5) \div 9.231 = 0.8375$   
 Required Injector Size =  $31.25 \div 0.8375 = 37.3 \text{ lb/hr (392 cc/min)}$

Central to the topic of injector sizing is the RPM at which the engine will need the injectors to fire. High RPM's shorten the amount of time between TDC events, thus shortening the maximum injector pulse width. The **Figure Below** shows the time per revolution as a function of RPM. The **Table** shows the peak injector pulse width (assuming an injector recovery time of **zero**) that is possible using both once-per-revolution firing and once-per engine-cycle (2 revolutions on a 4 stroke) firing modes. If the operating pulse width approaches the values in **Table E.1. 1**, the injectors are effectively "maxed-out." Larger injectors would be necessary if the engine needed more fuel. Note that the injector recovery time will be at least 1.0ms in practice. Consequently, the values given in **Table E.1. 1** should have 1.0ms subtracted from them to determine the actual pulse width peak.



**Figure:** Time between revolutions for various engine speeds.

| RPM   | Phase Sequential<br>(1 inj. per rev.)<br>(ms) | Full Sequential<br>(1 inj. per 2 rev.)<br>(ms) |
|-------|---|--|
| 0     | -   | -  |
| 500   | 120.0   | 240.0  |
| 1000  | 60.0  | 120.0  |
| 1500  | 40.0  | 80.0   |
| 2000  | 30.0  | 60.0   |
| 2500  | 24.0  | 48.0   |
| 3000  | 20.0  | 40.0   |
| 3500  | 17.1  | 34.3   |
| 4000  | 15.0  | 30.0   |
| 4500  | 13.3  | 26.7   |
| 5000  | 12.0  | 24.0   |
| 5500  | 10.9  | 21.8   |
| 6000  | 10.0  | 20.0   |
| 6500  | 9.2   | 18.5   |
| 7000  | 8.6   | 17.1   |
| 7500  | 8.0   | 16.0   |
| 8000  | 7.5   | 15.0   |
| 8500  | 7.1   | 14.1   |
| 9000  | 6.7   | 13.3   |
| 9500  | 6.3   | 12.6   |
| 10000 | 6.0   | 12.0   |
| 10500 | 5.7   | 11.4   |
| 11000 | 5.5   | 10.9   |
| 11500 | 5.2   | 10.4   |
| 12000 | 5.0   | 10.0   |
| 12500 | 4.8   | 9.6  |
| 13000 | 4.6   | 9.2  |
| 13500 | 4.4   | 8.9  |
| 14000 | 4.3   | 8.6  |
| 14500 | 4.1   | 8.3  |
| 15000 | 4.0   | 8.0  |
| 15500 | 3.9   | 7.7  |
| 16000 | 3.8   | 7.5  |
| 16500 | 3.6   | 7.3  |
| 17000 | 3.5   | 7.1  |
| 17500 | 3.4   | 6.9  |
| 18000 | 3.3   | 6.7  |
| 18500 | 3.2   | 6.5  |
| 19000 | 3.2   | 6.3  |
| 19500 | 3.1   | 6.2  |
| 20000 | 3.0   | 6.0  |

**Table** Peak injector pulse widths for phase- and full-sequential injector firing. Injector recovery time of zero is assumed.

## 3.2. Fuel Pump Selection

When choosing a fuel pump, two factors are important:

Flow Rating (in lbs/hr)

Pressure Rating (in psi)

To find the flow rating required for a given engine, multiply the engine horsepower by the BSFC, and add at least 25%.

Example:

400 HP Engine w/ 0.50 BSFC

Fuel Pump Required =  $(400 \times 0.50) + (400 \times 0.50 \times .25) = \mathbf{250 \text{ lb/hr minimum}}$

As for the pressure rating, a minimum of 70psi is typically used for multi-port injection layouts. Fuel pumps for TBI setups can be rated lower, since the operating rail pressure is lower with TBI injectors.

High-boost (over 20psi) applications may suffer from problems with normal OEM fuel pumps. Since many fuel pumps are rated at 43psi (3-Bar), there is no information on what the pumps will flow at 60 or 70psi.

On a turbo engine with 25psi boost, the fuel pump will see about 68psi. Most stock fuel pumps will not be able to maintain their flow rating at this pressure, and a lean-out condition may result. As such, it is highly advised that you buy a good quality aftermarket pump when running highly boosted engines.

If a high-pressure pump is mounted above the fuel level in a gas tank, a decreased pump lifespan will generally result. Some high-pressure pumps will fail very quickly when mounted above the fuel level. The reason for this failure is that high-pressure pumps often are not designed to pull suction. As such, any high-pressure pump mounted above the fuel level should have a low-pressure fuel pump before it. A standard carburetor-style fuel pump can be used for this task.

## 3.3. Fuel Pressure Regulator Selection

Unlike a stock OEM computer, the **TECs** generally does not require an adjustable fuel pressure regulator. The reason for this is quite simple: the **TECs** allows you to set the precise fuel injector pulse width for a given RPM/load point. In so doing, you do not need to change the fuel pressure to change the amount of fuel introduced into the cylinders; you simply need to change the injector pulse width.

There are, however, some guidelines to be followed for selecting a regulator. When you select the injector size needed for an engine, you will need to know the pressure for which the flow rate was established.

Typically, injector sizes are rated at 3-Bar or 43.5psi. Therefore, an injector rated at 55 lb/hr at 43.5psi will only flow 55 lb/hr *when it is at 43.5psi*. More accurately, it will only flow 55 lb/hr when the *pressure gradient* across the injector is 43.5psi.

The pressure gradient is defined as the difference between the injector spray tip pressure (this is generally the same as the intake manifold pressure) and the fuel rail pressure (often referred to as “gauge pressure”). For a naturally aspirated engine at idle making 15” of Hg (about -7.5psi) vacuum, you will need to decrease your fuel rail pressure by 15” of Hg (about -7.5psi) to obtain the same pressure gradient across the injector. So for the 55 lb/hr injector to actually flow 55 lb/hr when the manifold is under -7.5psi vacuum, you will need to decrease the fuel rail pressure by 7.5psi. The rail pressure should therefore be reduced from 43.5psi to 36psi.

The same holds true for engines under boost: for an engine with 10psi of boost pressure in the intake manifold, the injectors will need to have 10psi added to the fuel rail pressure. The fuel rail pressure would then have to be 53.5psi.

Though this all may sound complicated, maintaining a constant pressure gradient sounds more difficult than it really is. Since 99% of all fuel pressure regulators have a vacuum hose port on them, all you need to do is run a vacuum hose from your intake manifold (after the throttle) to the regulator. On boosted applications using a draw-through throttle, place the vacuum hose after the turbo compressor. To be

totally accurate, the vacuum/boost reference for the port on the regulator should be experiencing the same vacuum/boost as the injector tip. Plumb the hose accordingly.

Be aware that when you use a fuel pressure regulator that regulates the fuel pressure to a value that is not the same as the fuel injector flow rating pressure, the injector will no longer run at it's rated flow. That is, higher pressure will cause a higher flow rate. To keep things straightforward, try to run the fuel pressure for which your injectors are rated. Electromotive offers several regulators with different pressure ratings to make your search as easy as possible.

TECs Output Functions and

## 4. Wiring the TECs

### 4.1. Introduction

The task of installing a **TECs** wiring harness may seem a bit intimidating at first. However, by dividing the wiring installation into a few small jobs, it can be accomplished by most installers in a reasonable amount of time.

**WARNING:** Always disconnect the battery when doing ANY electrical work on a vehicle. Use common sense when working around electrical systems, particularly the **TECs** DFU coils. The voltage output of the coils can be well over 40,000 Volts at a given instant.

#### 4.1.1. A brief word on Crimp Terminals...

When crimping terminals to the sensor wires, care must be taken to ensure that a proper crimp is made. Improper crimps can lead to terminal failure and wire fatigue. To crimp properly, we recommend using a high-quality ratcheting crimp tool (such a tool is available from Electromotive). In the absence of a good crimp tool, the terminals can be soldered. Care should be taken to make absolutely certain that the solder penetrates the terminal and gets to the wire.

There are two main crimp styles used with the **TECs** sensors: Metri-Pack and Weather-Pack. Metri-Pack terminals have two crimp areas. One area crimps to the bare (stripped) wire and provides the electrical connection, and the other area crimps to the un-stripped wire housing to provide a strain relief. Metri-Pack connectors are pull-to-seat.

Weather-Pack terminals also have two crimp areas, but instead of one area acting as a strain relief, it is used to hold the connector seal in place. Therefore, when crimping a Weather-Pack terminal, always insert the cable seal before crimping. Weather-pack connectors are push-to-seat.

Note : Soldered terminals will not tolerate much flexing. They may break if too much movement is allowed.

#### 4.1.2. Other tips:

If your engine starts and maintains idle, but the idle drops too low when lifting off the gas and then rises slowly to the target RPM, a likely solution is to increase the Reset position. This will help to slow the rate that the RPM drops when lifting off the gas. You could also try a slight increase in falling rate sensitivity.

If the engine keeps shooting past the rpm target in both directions without stopping (RPM is oscillating), try reducing both proportional gains. These values should both generally be the same.

If the engine revs very high when starting (hard start), try decreasing the maximum duty cycle value. This will reduce the amount that the idle motor can open thus reducing how high the engine can rev on startup.

If when revving the engine, the engine rpm oscillates a little bit around the decel rpm while falling, reducing the reset value should help to prevent this. If the engine falls below the idle target and almost stalls, a larger reset value will help.

## 4.2. TECs - Main Power Connections

The two wires (with their own connector) that protrude from the **TECs** ECU are the main ground and switched ignition power. The ground wire is 10awg. The reason for the larger/thicker size of the wire is that the ECU is mainly in charge of switching the GROUND, not the +12 Volt power. As an example, the fuel injector and coil outputs are all pull-to-grounds. The +12 Volt power is supplied on a harness that is external to the **TECs**.

The red 12awg wire in position (A) on the 2-position connector should be connected to **Switched +12 Volt Input**. This wire is used to turn the unit on and off as well as supply power to the ECU. As such it only flows a very small amount of current (less than 1 amp). This wire can be placed on the ignition switch circuit or part of the coil relay output. The black 10awg wire in position (B) of the connector should be connected to full time battery negative. The **TECs** is shipped with the corresponding connector with five feet of wire. See **the Appendix** for a wiring diagram.

If you are using the **TECs** Power Harness, refer to the next section on installing the Switched +12 Volt Input into the Power Harness.

### 4.2.1. Power Harness Installation

Electromotive's Power Harness (PN 070-40000) for the **TECs** is capable of supplying the +12Volt high-amperage power required to run the DFU, injectors, EGO sensor heater and fuel pump. Included in the harness is a fuse block with four fuses (ignition, DFU's, Injectors and Fuel Pump are fused) and two relays to switch the power. Our custom harnesses are all built with the power harness pre-installed, so wiring them is even more straightforward. The **Figure Below** gives an example of a typical Power Harness installation.

#### Power Inputs

The Power Inputs are color coded in standard fashion:

|                   |                                  |
|-------------------|----------------------------------|
| Red 12awg Wire:   | Connect to (Switched +12V input) |
| Black 10awg Wire: | Connect to Vehicle Ground        |

#### Power Outputs (w/ switched voltage input)

The power outputs provide power for the DFU, injectors, EGO sensor heater, and Fuel Pump. The switched voltage input is used to turn on the **TECs** ECU, and should be wired to a +12Volt source that is activated with the ignition key.

|                            |   |
|----------------------------|---|
| Purple/White Stripe 16awg: | Injector Power (runs to all injectors)            |
| Red/White Stripe:          | DFU Power (pin "D" on DFU)                        |
| Green 16awg:               | Fuel Pump Positive and EGO Sensor Heater Positive |

The Wiring Diagrams in the DFU and Injector wiring sections of this manual show the terminals on which the power should be brought in. Any reference to fusing the power source in these sections is unnecessary when using the Power Harness, since the connections are already fused.

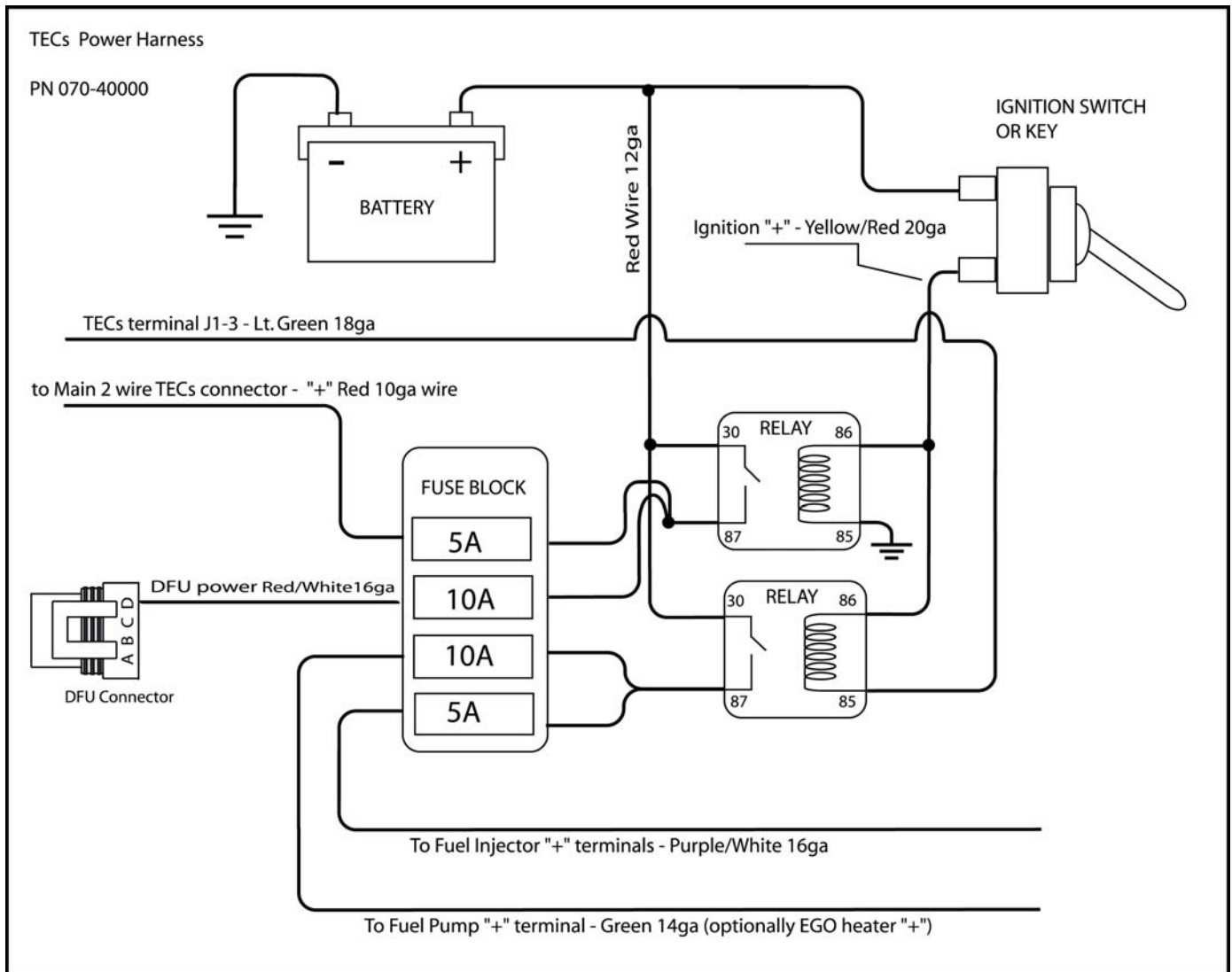


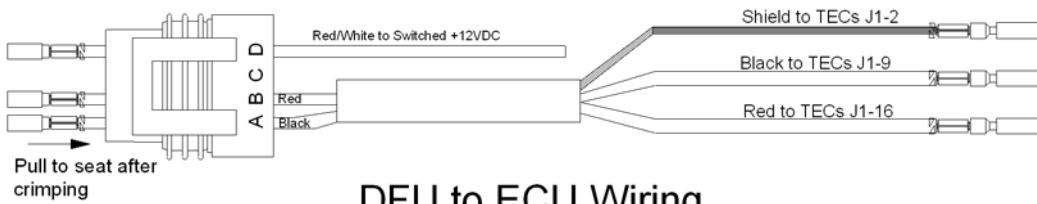
Figure A.5.1: TECs Power Harness (PN: 070-40000).

### 4.3. Wiring the DFU's

The first step in wiring the DFU's is to install the ground wire. The DFU's come from our factory with a ground wire pre-installed on a tapped, un-anodized hole. This wire **MUST** be connected to chassis/battery ground. **FAILURE TO DO SO MAY RESULT IN SEVERE ELECTRICAL SHOCK TO THE USER!!** Electrical shock will occur if the DFU is not grounded, and someone touches it while touching chassis ground (with the engine running). If desired, the ground wire may be relocated elsewhere on the DFU chassis. However, you will need to scrape off the anodization from the chassis at the point of contact, since the anodizing acts as an electrical insulator. Also, loose coil screws may cause an electrical shock as well, since they must be grounded to the case at all times. **Always make sure that both the coil screws and the ground wire are securely fastened.**

After the DFU has been grounded, the rest of the wiring may begin. The DFU's come shipped with the appropriate connectors. Terminal D on all DFU's should be connected to a **FUSED 12 VOLT SOURCE** that can pull **9 AMPS** of current. In the wiring harness, the outputs for Coils A and B, are routed in the same shielded-cable housing. These are all 9amp pull-to-ground outputs; that is, they create a ground path every time a coil charges. When the coils fire, the outputs "float," with no connection to ground or power. If the wires need to be spliced or lengthened, 16awg wire should be used. See **Figure Below** for details on the coil outputs in the wiring harness.





## DFU to ECU Wiring

(note: Shield wire is connected at the TECs unit but not connected at the DFU)

**Figure:** ECU Coil Output Wires

### WARNING:

The DFU chassis **MUST** be grounded. A ground wire must be connected to battery negative, or to a good chassis ground. **FAILURE TO GROUND THE DFU'S MAY RESULT IN SEVERE ELECTRICAL SHOCK!** Also, poorly grounded DFU's may result in poor engine performance, and can cause engine damage!! Use the drilled and tapped hole next to the yellow connector for the ground wire. If desired, the unit may instead be grounded at one of the four bolt holes. However, **you will need to scrape off the anodizing under the bolt head**. The anodizing is an electrical insulator, so unless it is scraped down to bare aluminum, it will not provide a good connection to ground. If more than one DFU is used on a vehicle, each one will require its own ground wire.

Additionally, make sure that the **coil screws** are fully tightened at all times!!

### 4.3.1. Pinout of the Direct Fire Unit (DFU)

**The DFU connector uses pull-to-seat terminals. DO NOT crimp the terminals onto the wires until you have fed the wires through the connector!**

When wiring the DFU, the correct sparkplug wiring must be determined for your application. DFU's for 4 cylinder engines have 2-coils. Each coil drives two spark plugs in waste-spark ignition setups. Two cycle applications will use single tower coils as well. The DFU's are driven by a 12volt charging system housed in the **TECs** ECU.

The 2-coil DFU's utilize three of the four terminals in their yellow connector. Here is the pin out:

|            |                                    |
|------------|------------------------------------|
| Terminal A | Ground Pulse for Coil A            |
| Terminal B | Ground Pulse for Coil B            |
| Terminal C | Unused                             |
| Terminal D | Full-Time +12 Volt Source (9 amps) |

On a standard inline 4-cylinder four-stroke application, this DFU will be used.

### 4.3.2. DFU to Spark Plugs

The coils fire in a specific order for each engine configuration. The proper coil must be connected to the correct cylinder in the firing order.

#### 1.1.1.3. Coil Notation

The following notation is used when referring to coils. A letter and a number are combined to identify a coil. The letter refers to the coil location on the DFU. The coil located closest to the connector is Coil A. The coil next to it is Coil B. If the DFU contains three coils, the last coil is Coil C. The number identifies the DFU that the coils are on. In an engine configuration using only one DFU, the number following the letter is 1. Coil notation is shown in Figure C.2.1.

Note: Each coil has two towers for spark plug wires. The towers are identical and should be thought of as the same coil. For example, if the engine setup guide refers to cylinder 1 and 4 connected to Coil A, you can connect your spark plug wires for the respective cylinders to EITHER tower.

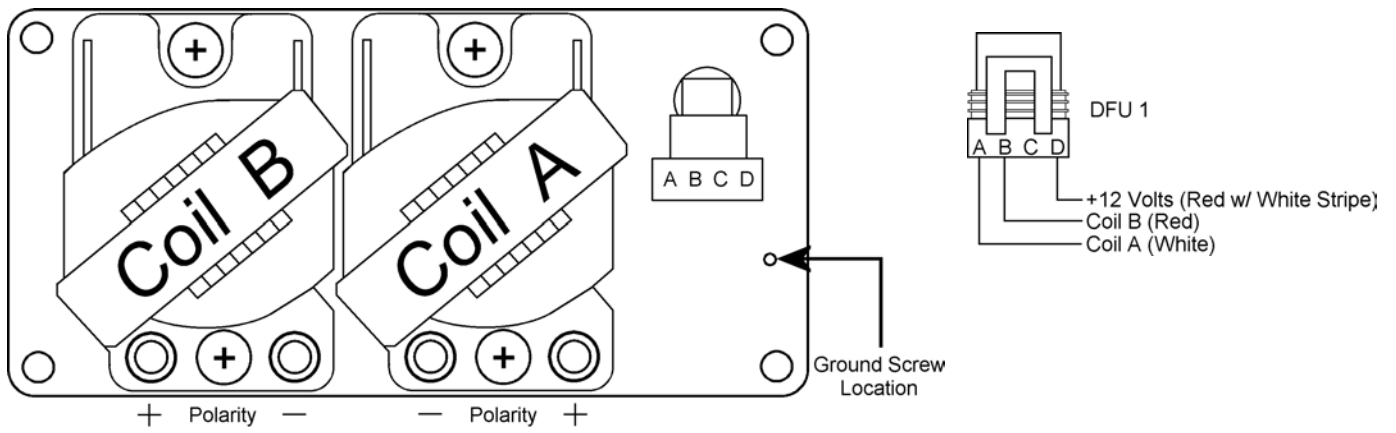


Figure: 4-Cyl DFU Setup

### 4.3.3. Spark Plug Wire Routing

For the engine to run correctly, the coils must be connected to the appropriate cylinders. Since the Electromotive DFU's utilize waste-spark coils, it is necessary to know the firing order of an engine to determine which cylinders should be paired together.

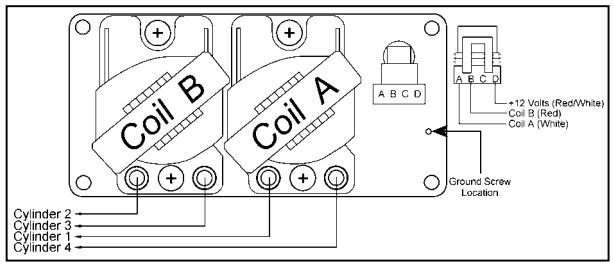
When a 1, 2, or 4-cylinder engine is chosen in the software setup, coil channels A and B will be fired alternately, every 180° of crankshaft rotation. The firing goes: **A – 180° – B – 180° – A – 180° – B –** etc...

### 4.3.4. Common Engine Setups

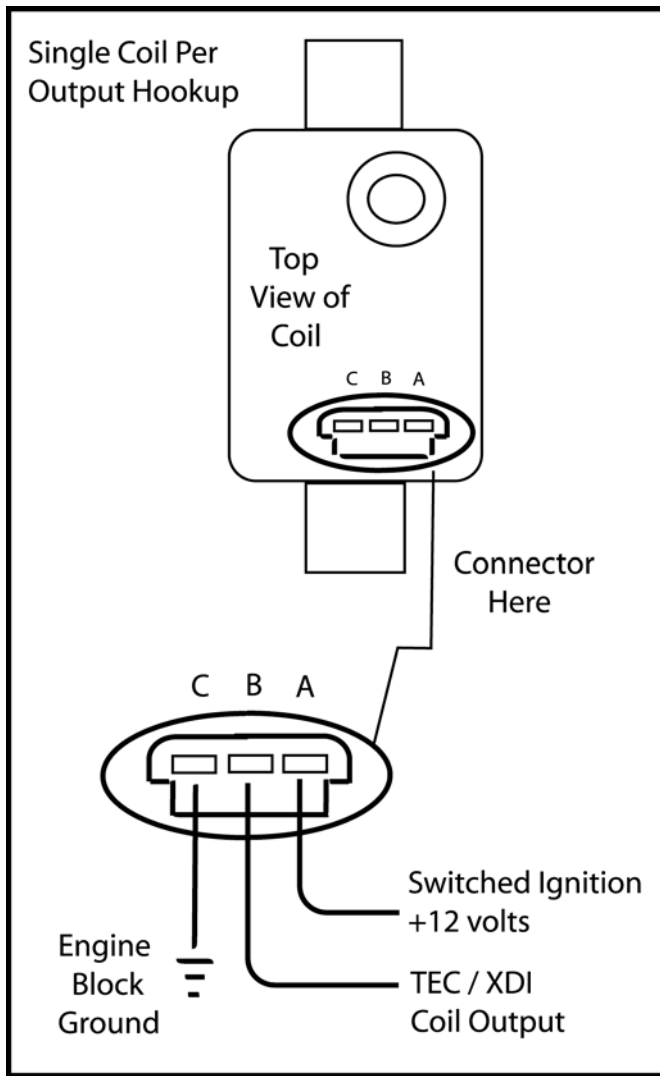
**Engine: 4-cylinder**  
**Firing Order: 1-3-4-2**

Coil Firing Order:            **A      B      A      B**  
 Engine Firing Order:        **1      3      4      2**  
 Cylinders 1&4 are paired to Coil A1. Cylinders 2&3 are paired to Coil B1.

### 4.3.5. Examples of Typical Engine Setups



**Figure C.4. 1:** Typical In-Line 4-cylinder DFU wiring. Firing Order 1-3-4-2 depicted here.



#### 4.3.6. Common Firing Orders

→ Remember, coils are fired in the following sequence:  
4 cylinder: A-B-A-B

| 4 cylinder -               | Firing Order | Coil |     |
|----------------------------|--------------|------|-----|
|                            |              | A    | B   |
| Most Inline 4-cyl Engines: | 1-3-4-2      | 1&4  | 3&2 |
| VW Flat 4 (air-cooled):    | 1-4-3-2      | 1&3  | 4&2 |
| Dual Plug 4-cyl:           | 1-3-4-2      | 1&4  | 3&2 |

#### 4.3.7. To find the TDC Event Order

Turn the engine to TDC #1.

Rotate the engine in its normal direction of rotation.

Record the order in which the cylinders have TDC's. It does not matter that the TDC events are mixed between compression and exhaust during this process.

#### 4.3.8. Spark Plug Wire Selection

The **TECs** outputs an extremely high-energy charge for the ignition coils. Resistor (carbon) core wires work best with this charging method, since they absorb electrical noise generated by the coil firing

events. Use 8mm or larger RFI and EMI suppression wire with GM boots. We recommend using a carbon core-style suppression wire with a resistance of 3,000 to 5,000 ohms per foot. **SOLID CORE WIRES SHOULD NEVER BE USED.** Do not be misled by spark plug wire manufacturers claiming to give you a “power increase” from their wire. The bottom line is that with our charging method, different spark plug wires simply do not make a difference in terms of spark energy. However, there is a huge difference in noise generated by different spark plug wire types (solid core wires generate a very high amount of noise with our system).

**Quoted from Magnecor’s Website:**

“What is not generally understood (or is ignored) is that the potential 45,000 plus volts (with alternating current characteristics) from the ignition coil does not flow through the entire the length of fine wire used for a spiral conductor like the 1 volt DC voltage from a test ohmmeter, but flows in a magnetic field surrounding the outermost surface of the spiral windings (skin effect). The same skin effect applies equally to the same pulsating flow of current passing through carbon and solid metal conductors. A spiral conductor with a low electrical resistance measured by a 1 volt DC ohmmeter indicates, in reality, nothing other than less of the expensive fine wire is used for the conductor windings!

Electrical devices, including spark plugs, use only the electrical energy necessary to perform the function for which such devices are designed. Spark plug wires are nothing more than conductors, and whereas a bad ignition wire's inefficient conductor can reduce the flow of electricity to the spark plug, an ignition wire that reportedly generates an "increase" in spark energy will have no effect on the spark jumping across the spark plug gap, since the energy consumed at the spark plug gap won't be any more than what is needed to jump the gap. For a more obvious example of this, a 25watt light bulb won't use any more energy or produce any more light if it's screwed into a socket wired for a 1000watt bulb.”

Due to the extremely high energy in the **TECs** coil charging circuit, spark plug wires may wear out faster than with a standard ignition. As such, it is recommended that the wires be checked periodically for carbon tracking caused by a breakdown of the internal conductor element. Looking at the plug wires in a dark area and wetting them with a spray bottle of water will reveal carbon tracking. Pay close attention to the exposed section of the spark plug (where the rubber boot ends) during the test. To maximize spark plug wire life, keep the lengths as short as possible (i.e. mount the DFU as close to the engine as possible). Replacement of the wires on an annual basis is recommended for high-rpm/high-horsepower applications.

For an extremely high-quality wire with excellent noise suppression, we recommend the Magnecor brand. Specifically, their “Electrosports 80” 8mm wire is very good with our system. Custom wire lengths and ends are available from them so you will not need to crimp the wires yourself. They can be reached at (248)669-6688 or on the web at: [www.magnecor.com](http://www.magnecor.com) . Taylor Pro-Wire Silicon Resistor wires also work well.

#### **4.3.9. Spark Plug Selection**

As was previously stated, spark plugs are generally more important to spark quality than spark plug wires. Most spark plugs exhibit failure when exposed to a large load. Failure usually consists of either intermittent sparking or arc-over. Arc-over is when the spark occurs between the spark plug wire and the engine block, instead of at the plug tip. Arc-over is exacerbated by the use of low-quality wires, or wires that have cuts in the insulation.

The load at which a spark plug fails is different for all spark plugs. With the **TECs’s** charging circuit, the more load you put on an engine, then more voltage will be applied to the plug. This is a beneficial situation: for a high compression engine, the voltage at the plug will be inherently higher (since there is more load). The detriment is that spark plugs and wires are only rated to a certain voltage (30-40,000 volts is typical), and can begin to “blow out” at around 40,000 volts. If that voltage is exceeded by a large amount for a long enough length of time, the spark plugs will either blow out, break down or arc to somewhere other than the electrode (often through the insulator directly to the engine block).

The solution is to run smaller plug gaps on high-compression engines. This is perfectly acceptable with our ignition charging method, since the high load of the cylinder pressure will allow the voltage to be quite

high at the electrode, but the small gap will keep the plug from seeing an over-voltage situation. Use the recommendations below as a guideline for spark plug gaps:

|                                    |                             |
|------------------------------------|-----------------------------|
| Stock Street Engine                | 0.045"-0.060" (1.1mm-1.5mm) |
| High Performance Street            | 0.030"-0.035" (.75mm-.9mm)  |
| Alcohol High Compression           | 0.025" (0.65mm)             |
| High Power 75 -115 HP per Cylinder | 0.025" (0.65mm)             |
| Over 115 HP per Cylinder           | 0.022" (0.55mm)             |
| Over 12:1 CR or Over 14psi Boost   | 0.022" (0.55mm)             |

Use of resistor plugs is highly recommended for optimum noise suppression. If using anything other than a resistor spark plug wire, a resistor plug **MUST** be used. The bottom line is this: the **TECs** system uses an *inductive* (long duration charge at battery voltage) charging method for the coils, which is completely different than the *capacitive* (short duration charge at higher-than-battery voltage) charging method used by several other aftermarket manufacturers. What may work well for these systems may not work well for ours. Following our recommendations about spark plug and wire selections will yield excellent results.

## 4.4. Fuel Injector Wiring

### 4.4.1. Wiring the Fuel Injectors

**The injector connectors use pull-to-seat terminals. DO NOT crimp the terminals onto the wires until you have fed the wires through the connector!**

Injector drivers 1-4 use a Yellow base color. The stripe color indicates the channel (Black-Red-Green-Blue = Channel 1-2-3-4).

All injectors need a +12Volt connection on one terminal and a **TECs** Injector Output on the other terminal. Only High Resistance injectors can be used and may be wired in pairs (in parallel) or singles.

### 4.4.2. Injector and Firing Patterns for EVEN-FIRE 4 Cylinder Engines

The injector outputs fire in one of two patterns.

#### **Phased:**

Injector 1 (J1-23) fires with Coil A and once every crankshaft revolution

Injector 2 (J1-6) fires with Coil B (180 degrees later) and once every crankshaft revolution

Typical 4 cylinder Phased Injector Connections:

| Firing Order | Injector Channel | Injector Terminal | Ignition Coil |
|--------------|------------------|-------------------|---------------|
| Cylinder 1   | 1                | J1-23             | A             |
| Cylinder 3   | 2                | J1-6              | B             |
| Cylinder 4   | 1                | J1-23             | A             |
| Cylinder 2   | 2                | J1-6              | B             |

In this mode Channels 3 and 4 may be used as additional GPOs.

#### **True Sequential:**

Injector 1 (J1-23) fires with Coil A and once every two revolutions

Injector 2 (J1-6) fires with Coil B and 180 degrees later

Injector 3 (J1-4) fires with Coil A and 180 degrees later

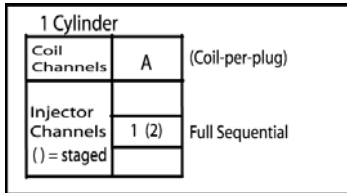
Injector 4 (J1-1) fires with Coil B and 180 degrees later

Typical 4 cylinder True Sequential Injector Connections:

| Firing Order | Injector Channel | Injector Terminal | Ignition Coil |
|--------------|------------------|-------------------|---------------|
| Cylinder 1   | 1                | J1-23             | A             |
| Cylinder 3   | 2                | J1-6              | B             |
| Cylinder 4   | 3                | J1-4              | A             |
| Cylinder 2   | 4                | J1-1              | B             |

In this mode GPO3 & 4 are lost.

### 4.4.3. Injector and Coil Firing Patterns for 2-CYCLE Engines

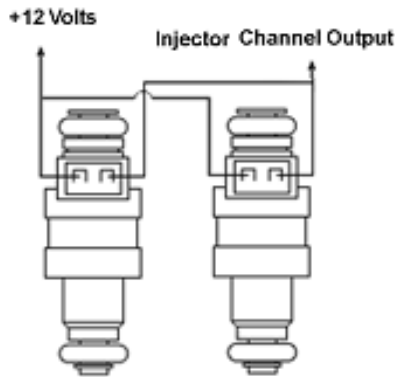


### 4.4.4. High vs. Low Impedance Injectors

The **TECs** is equipped with 4 fuel injector channels. These channels are pull-to-ground outputs, meaning that they provide a ground connection for the injectors when they fire. The injector channels cannot operate peak and hold type low resistance injectors. To differentiate between high and low impedance injectors, simply measure the resistance across the two terminals on the injector. If the resistance is around 2.5 ohms, it is a low impedance injector. If the resistance is around 1.2 ohms, it is a throttle body-style injector. If the resistance is above 12 ohms, it is a high impedance injector. Low resistance injectors are used when the injector is large and finer control of the low opening time is required. Most OEM injectors are smaller and are of the high resistance type.

**Table D.1. 1:** Recommended fuel injector selection for various wiring configurations. Note that the values given are for individual injector resistance, NOT for the total circuit resistance. TBI-style injectors cannot be run with a **TECs**.

| Injector type  | Individual Injector Resistance for 1 Injector per Driver | Individual Injector Resistance for 2 Injectors per Driver |
|----------------|--|---|
| High Impedance | 6 ohms or above  | 12 ohms or above  |



**Figure D.1. 1:** Parallel wiring of fuel injectors. Note that injectors have an electrical polarity. Typically, positive is on the side marked above.

#### 4.4.5. Injector Firing Schemes

Most engines will operate quite well using a phased-sequential injector firing mode. This firing mode pairs injectors together just like the waste-spark coil firing scheme. On a standard inline 4-cylinder four-stroke engine, cylinders 1 and 4 will always be on top dead center at the same time, but one cylinder will be on compression when the other is on exhaust. The same hold true for cylinders 2 and 3. As a result, it is possible to use just two injector channels to drive four low (or high) impedance injectors for this engine: simply pair the injectors for cylinders 1 and 4 to channel 1, and the injectors for cylinders 2 and 3 to channel 2. If a phase-sequential firing scheme is chosen in the software, each channel will fire once per revolution. This means that each cylinder will receive a pulse of fuel twice per engine cycle (once per revolution on a 4-stroke). This type of firing scheme requires only the standard Electromotive 60(-2) tooth trigger wheel on the crankshaft. No cam sensor is required. For an outline of the various firing options available with the **TECs**, see the tables in Section C.3.

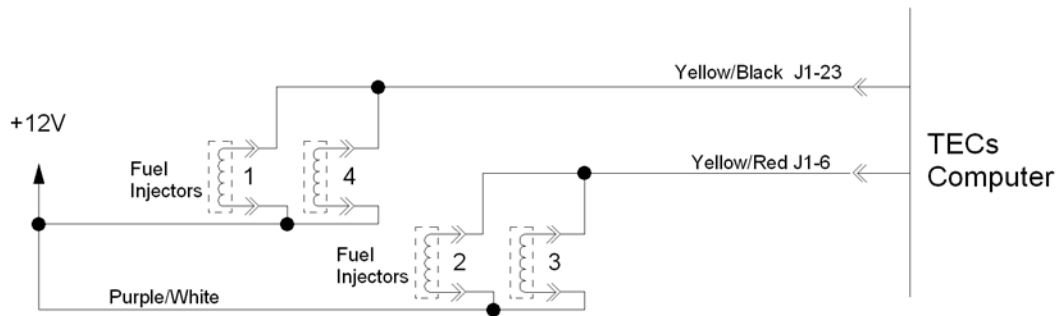
Regardless of engine firing order, the **TECs** fires its injector output channels in numerical order 1-2-3-4. Injector channels must be wired appropriately to match an engine's firing order.

- If an injection mode does not use all four output channels, it will reset after its intended number of channels have fired. As an example, a 4-cylinder phase-sequential setup will fire 1-2-1-2-1-2-etc. The remaining channels can be used at GPO outputs.

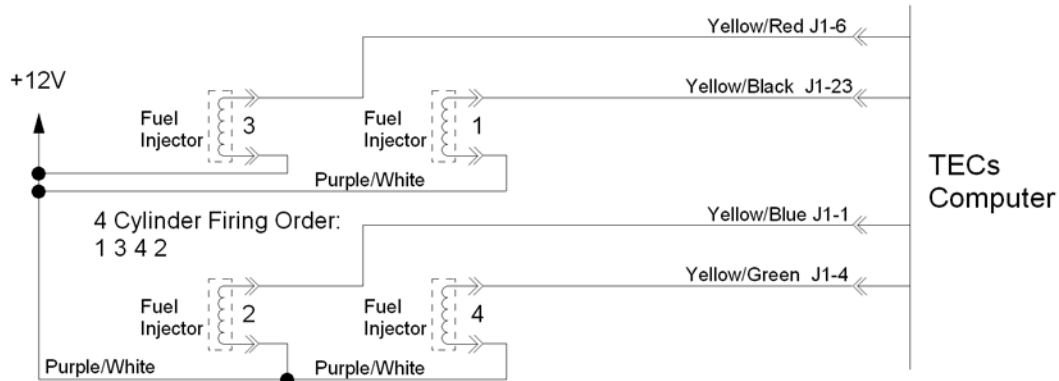
If your desired injector firing scenario is not listed, it is advised that you call Electromotive Technical Support.

#### 4.4.6. Phased Injection

Most applications will use the phased firing option. This firing scenario pairs cylinders that share their TDC's to the same injector channels. As such, one injector channel fires two injectors: one on compression and the other on exhaust. Each injector channel will fire once per revolution, so each cylinder will see a shot of fuel on both the exhaust and compression stroke.



Phased Injector Wiring



True Sequential Injector Wiring

#### 4.4.7. True Sequential Injection

The biggest difference between true sequential injection and other injection types is that true sequential injection requires the use of a cam trigger in addition to the crank trigger. The cam trigger is used to provide a reference pulse for Top Dead Center compression. The crankshaft trigger knows the location of TDC, but on a 4-stroke engine, TDC is not all that is needed to determine which cycle the engine is on. For this, a camshaft reference is needed. With a full sequential setup, each injector channel is independent, and each injector is fired once per engine cycle (every two revolutions on a four stroke) on the end of the exhaust stroke.

### 4.5. Idle Air Control



### 4.5.1. Idle Air Control Valve

The Idle Air Control (IAC) Valve is responsible for maintaining a smooth engine idle. Using the Wintec software, the IAC valve can be made to increase idle speeds during cold engine operation or air conditioner turn-on. The IAC valve control built into the **TECs** can be used with a two-wire solenoid type Idle Air Valve. **TECs** cannot operate 4 wire stepper motor-style IAC's. The solenoid valve allows the pintle of the IAC valve to move in and out very quickly to allow varying amounts of air into the intake manifold. This way, even with the throttle closed, the IAC valve can supply additional air to the engine. See **Figure** for an IAC valve plumbing diagram. See **Figure 3** for IAC wiring instructions. **The Software Manual** covers the tuning of the IAC Parameters.

The idle speed control air passages must be able to supply enough air to the engine so that it can have an effect on engine speed. Therefore, be sure to use at least a 1/2" hole for the air bypass passages.

For individual throttle applications, it will be necessary to use a balance tube to bring all the throttles to the IAC Valve. This will allow each cylinder to be filled equally by the bypass air. A minimum of 1/2" inner diameter plumbing should be used for the balance tube to allow for adequate cylinder-to-cylinder consistency.

The most common IAC valve is the type used on Fords. Find a variation that allows the installation of rubber hoses onto the housing. One hose can then be run to the intake plenum with the other hose going to filtered air.

**With all Idle Air Control Valve setups, always make sure that the engine is receiving filtered air from the air bypass passages.**

**The IAC will not be activated unless the TPS voltage is BELOW the "TPS Closed Throttle Voltage" value. As an example, if the TPS voltage is 1.5 volts when the throttle is fully closed, the IAC valve will not be activated unless the "TPS Closed Throttle Voltage" setting is **GREATER THAN 1.5 volts.****

### 4.5.2. Wiring a 2-wire IAC:

A 2-wire IAC should be wired as shown in Figure 3. The diode shown is required on all idle motors except some Ford motors. If the Ford IAC you are using had a diode across it in the original wiring harness, it is recommended that you use the original diode. If you never had an original harness, a diode should be used just to be safe. The Radio shack part will work in this case. Care must be taken to be certain that the polarity on the Ford motor is also correct. For those of you outside the U.S., Malpin carries diodes of similar spec to the Radio shack part.

### 4.5.3. Wiring a 3-wire IAC:

The 3-wire IAC requires the use of the 2-wire to 3-wire IAC adapter module. Contact your Electromotive dealer to get this part. The wiring is as follows: Switched +12v source to the center lead of the IAC and pin D of the IAC Adapter. IAC Adapter, pins A and B go to the outer leads of the IAC valve. If the IAC valve appears to be working backwards, reverse the wires to the two outer leads of the IAC valve. Pin C from the IAC adapter connects to the signal wire from the **TECs** GPO output. The case of the adapter **MUST** be grounded. This setup does not require any diodes.

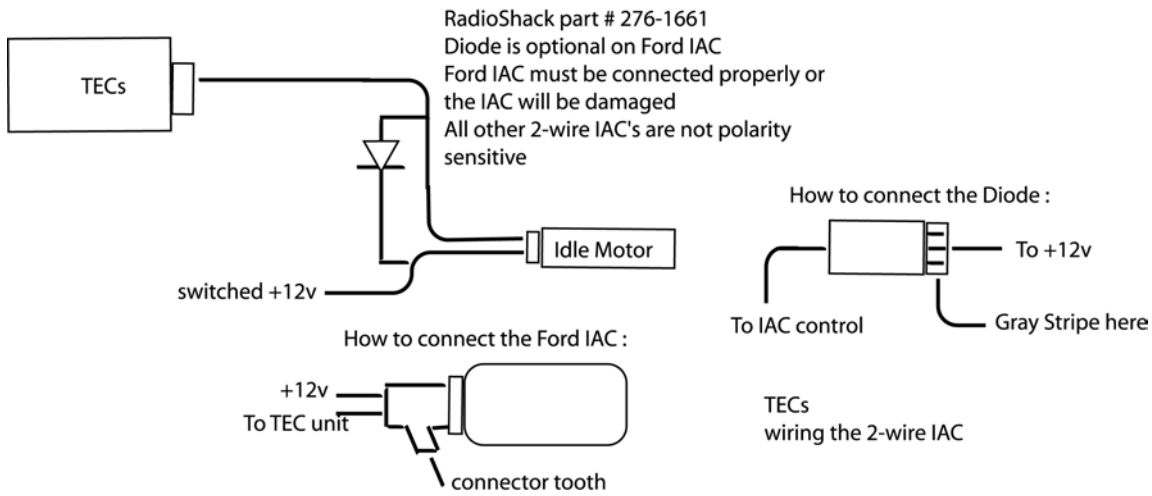
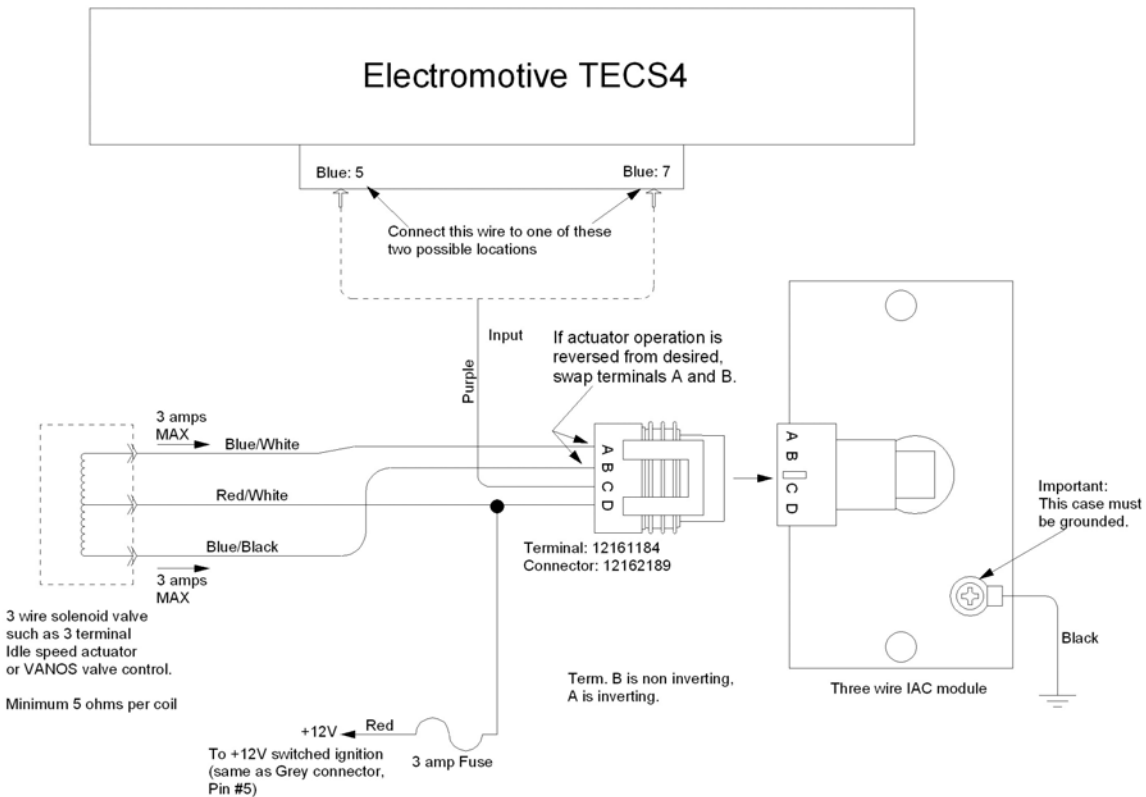


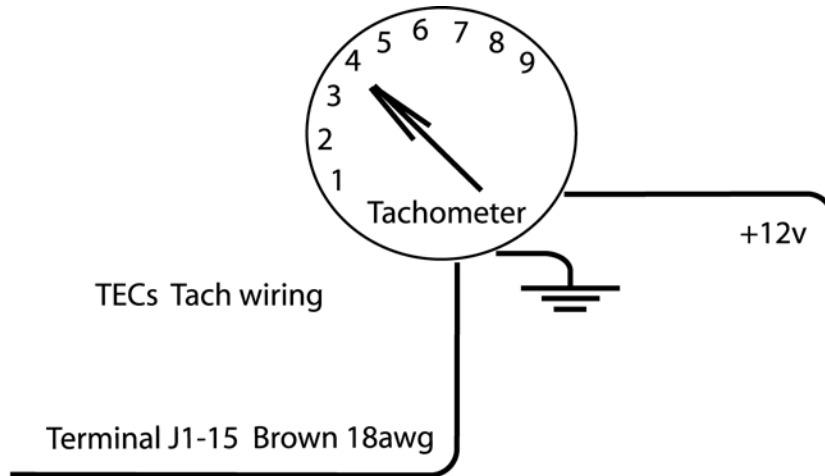
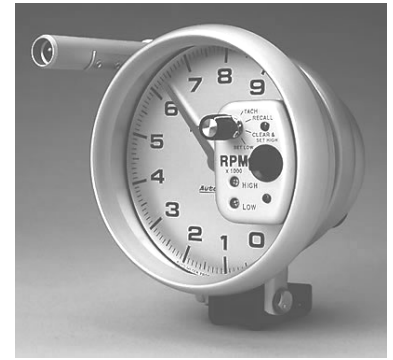
Figure 3 – Wiring the 2-wire IAC



Wiring 3-wire IAC module

## Tachometer Output

The tachometer output on the **TECs** is a +12 Volt square wave. Each time a coil fires, a “tach pulse” is generated. Therefore, the output from the tachometer signal is ground, then +12 Volts for 30 degrees of crankshaft rotation starting at each TDC/spark event. A 4-cylinder will output 2 tach pulses per revolution. For applications that have a tachometer configured for a different number of cylinders than the engine there is the option of



changing the tach output type in the software.

This type of signal is compatible with most new-style tachometers. However, some older tachometers trigger off the high-voltage signal from the ignition coil (C-). These types of coils require the use of a tachometer amplifier, since they are designed to trigger off of a 120 Volt signal. Tachometer amplifiers (PN: 150-15210) are available from Electromotive to suit these applications.

Figure F.2.1: Typical tachometer wiring.

## 4.6. Fuel Pump Relay Output

The fuel pump output is designed to provide activation of the fuel pump relay on a vehicle. It is NOT designed to power the fuel pump directly. See **Figure** for wiring instructions. The software allows the user to define the amount of time that the fuel pump primes the system when the **TECs** is first turned on. This ensures adequate fuel rail pressure on start-up. When the **TECs** is first turned on, the fuel pump will run for the amount of time defined in the software. If the engine is not cranked during or after this time, the fuel pump will turn off. Once the engine is cranked, the fuel pump will turn back on. Essentially, the fuel pump should always be running when the engine is rotating.

### CAUTION:

Do NOT connect the fuel pump relay output directly to the fuel pump. This will cause an excessive amount of current to be drawn through the circuit, and may result in damage to your **TECs**.

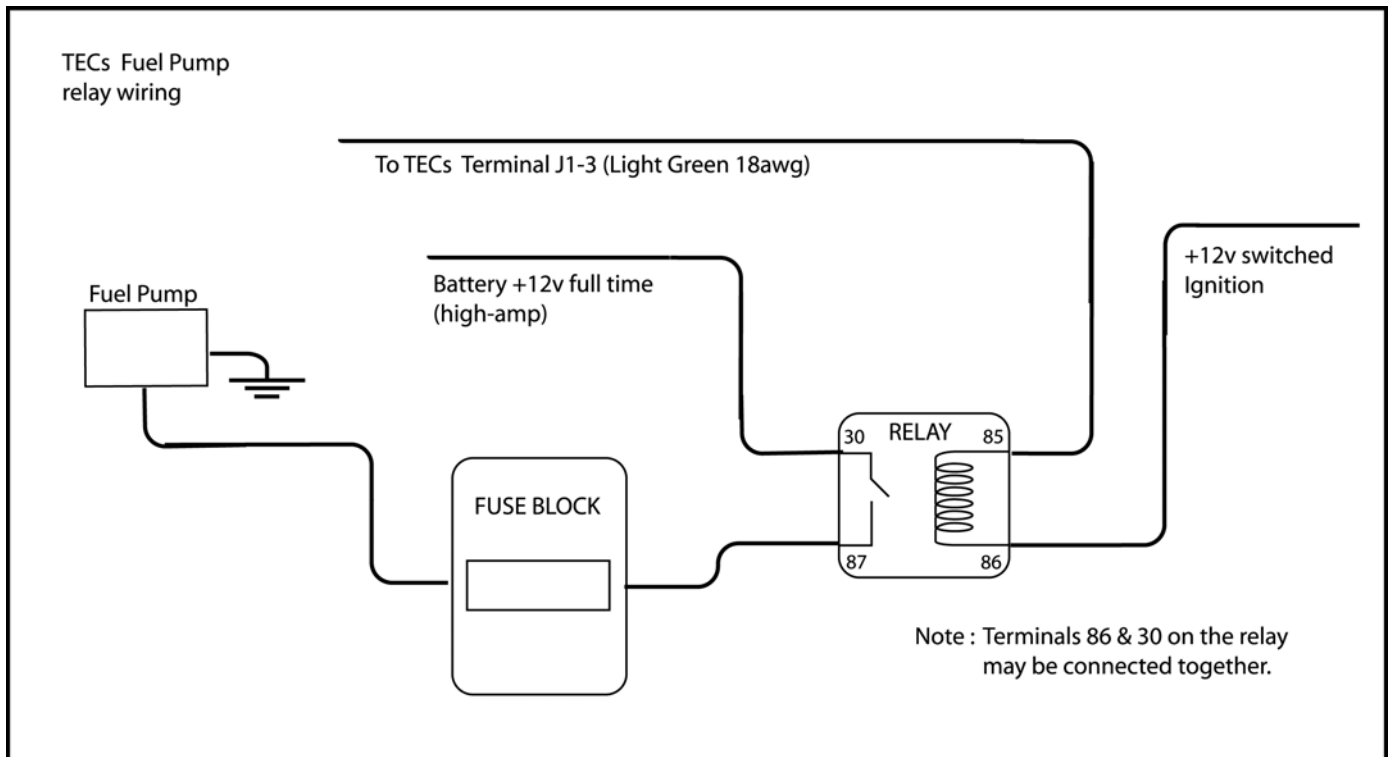


Figure: Fuel pump relay wiring.

## 4.7. Wiring the Sensors

The **TECS** harness has provisions to connect all of the engine devices outlined in the following **Sections** of this manual. Refer to this section to wire your sensors appropriately.

The following sensors use pull-to-seat connectors (feed the wire through the connector before crimping the terminal!):

- Coolant Temperature
- Manifold Air Temperature
- Some Throttle Position Sensors

- The following sensors use push-to-seat connectors (crimp the terminal to the wire before inserting into the connector!):

- Crank Sensor
- Cam Sensor (if used)
- MAP sensor (1-Bar sensors use green connector. 2- & 3-Bar use orange connector)
- Some Throttle Position Sensors
- EGO Sensor
- Knock Sensor

### 4.7.1. Manifold Air Pressure (MAP) Sensor

The MAP sensor determines the operating load of the engine. To do so, it measures the intake manifold absolute pressure. Since the intake manifold pressure has a direct effect on the amount of air that the cylinders can ingest, the use of a MAP sensor as a load-determining device is well justified.

MAP sensors are available from Electromotive in three varieties: 1-, 2-, and 3-Bar. A 1-Bar sensor would be used on a naturally aspirated engine, a 2-Bar sensor would be used on a boosted engine (up to 15psi), and a 3-Bar sensor would be used on a boosted engine (up to 30psi).

The output of a MAP sensor is a 0 to +5 Volt signal. When the intake manifold pressure is low (high vacuum), the sensor reading is low (approaching 0 Volts). This would occur during part-throttle cruising or decelerating (engine braking). When the intake manifold pressure is high (low vacuum), the sensor reading is high (approaching +5 Volts). This would occur during full throttle operation.

### Absolute vs. Gauge Pressure...

A MAP sensor is an absolute sensor. This means that its readings are referenced to a full vacuum. As such, the lowest reading attainable on a MAP sensor would be a full vacuum. (In practice, however, most MAP sensors only go down to about 10kPa.)



Gauge pressure is referenced to ambient atmospheric pressure. When we say that an engine is running 15psi (103kPa) of boost, it means that the intake manifold is seeing 15psi of positive pressure. Since standard atmospheric pressure is approximately 14.7psi (101.3kPa), the absolute manifold pressure for this engine would be 29.7psi (205kPa or about 2 Bar). Thus, a 2-Bar sensor is necessary for this engine. Refer to the formula below if you are confused about the difference between gauge and absolute pressure.

$$\text{Ambient (atmospheric) Pressure} + \text{Gauge Pressure} = \text{Absolute Pressure}$$

When discussing absolute pressure, there is no distinction made between vacuum and pressure.

When discussing gauge or relative pressure, vacuum readings will be negative values and boost readings will be positive. Alternatively, in the US measurement system, vacuum readings can be expressed in inches of Mercury and boost can be expressed in pounds per square inch.

### Units of Measurement

In the US, units of vacuum are typically measured in inches of mercury (in-Hg). Units of pressure are typically measured in pounds per square inch (psi). Since there is a distinction made between vacuum and pressure readings, these units are generally not used for absolute measurements.

In most other countries, the metric system is used for pressure measurements. In this system, the kilopascal (kPa) is the standard unit of measurement. The distinction must be made to whether the measurement is in absolute kPa or gauge kPa. Typically, this is done by writing “kPa, abs” for the former, and “kPa, gauge” for the latter. For the purposes of this section, we will treat all kPa reading as *absolute* readings. The Chart below gives conversion data for US and metric units.

$$\text{Ambient (atmospheric) Pressure} + \text{Gauge Pressure} = \text{Absolute Pressure}$$

1psi = 6.895 kPa

1 in-Hg = 3.377 kPa

1 Bar = 101.3kPa, abs = 0psi, gauge

2 Bar = 202.6kPa, abs = 14.7psi, gauge

3 Bar = 303.9kPa, abs = 29.4psi, gauge

**Table:** US to metric unit conversion data.

| kPa      | in-Hg/psig |
|----------|------------|
| Absolute | Gauge      |
| 0        | 29.9 in-Hg |
| 10       | 27.0 in-Hg |
| 20       | 24.0 in-Hg |
| 30       | 21.1 in-Hg |
| 40       | 18.1 in-Hg |
| 50       | 15.2 in-Hg |
| 60       | 12.2 in-Hg |
| 70       | 9.28 in-Hg |
| 80       | 6.31 in-Hg |
| 90       | 3.35 in-Hg |
| 100      | 0.39 in-Hg |
| 110      | 1.26 psi   |
| 120      | 2.71 psi   |
| 130      | 4.16 psi   |
| 140      | 5.61 psi   |
| 150      | 7.06 psi   |
| 160      | 8.51 psi   |

| kPa      | in-Hg/psig |
|----------|------------|
| Absolute | Gauge      |
| 170      | 10.0 psi   |
| 180      | 11.4 psi   |
| 190      | 12.9 psi   |
| 200      | 14.3 psi   |
| 210      | 15.8 psi   |
| 220      | 17.2 psi   |
| 230      | 18.6 psi   |
| 240      | 20.1 psi   |
| 250      | 21.6 psi   |
| 260      | 23.0 psi   |
| 270      | 24.4 psi   |
| 280      | 25.9 psi   |
| 290      | 27.4 psi   |
| 300      | 28.8 psi   |
| 310      | 30.3 psi   |
| 320      | 31.7 psi   |
| 330      | 33.2 psi   |

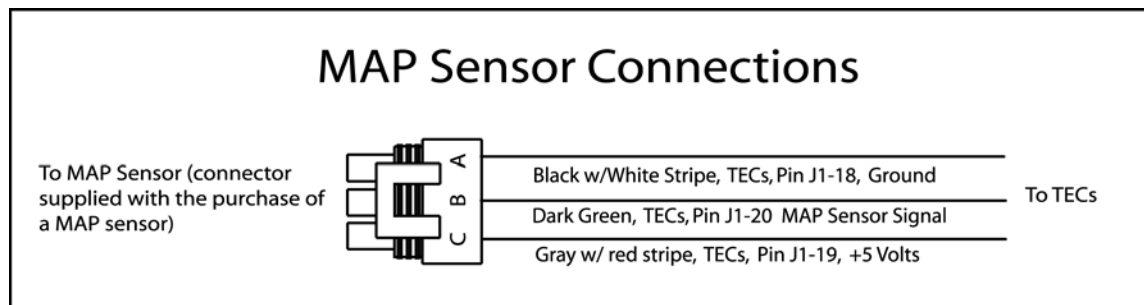
## MAP Sensor Data

To check that the MAP sensor is working correctly, and to check for the MAP sensor Bar number (1-, 2-, or 3-Bar), it is necessary to know the output voltage from the sensor as a function of pressure. With the **TECs** turned on, but the engine NOT running, the MAP sensors will output the voltage for atmospheric pressure (since manifold pressure is equal to the atmospheric pressure when the engine is not running). At standard atmospheric conditions (101.3 kPa), the output voltages should be:

- 1-Bar: approximately 4.80 Volts
- 2-Bar: approximately 2.30 Volts
- 3-Bar: approximately 1.55 Volts

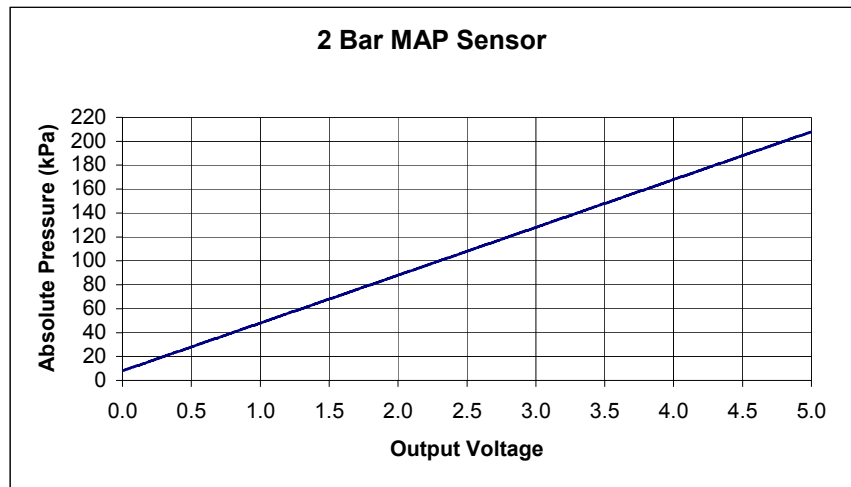
Note that the output voltage should be measured between pin “B” (output) and pin “A” (ground). If the sensor does not output a voltage near the above numbers, the sensor is likely defective. Refer to the **Figure below** for MAP sensor wiring instructions. Refer to **Figures** for MAP sensor voltage as a function of manifold pressure for the three MAP sensors.

**Figure:** MAP sensor wiring.

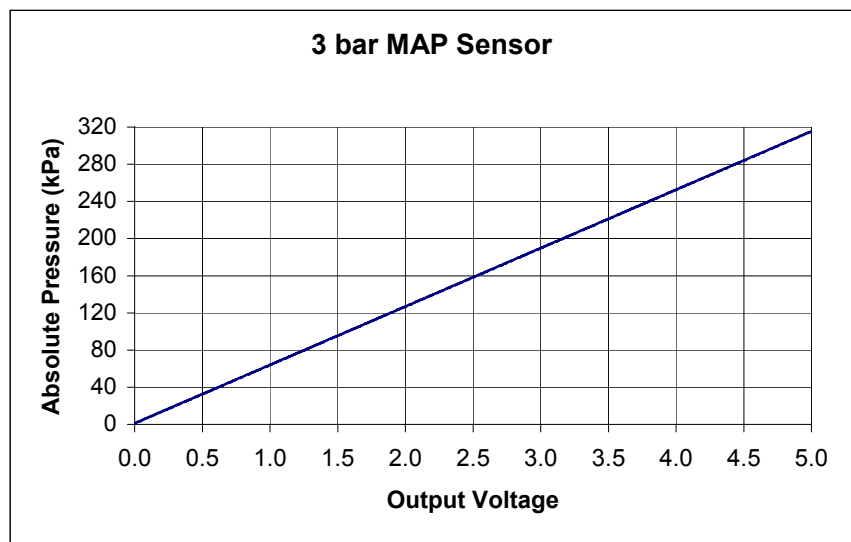


**Figure: 1-**  
Bar MAP  
sensor  
output  
voltage.

**Figure: 2-**  
Bar MAP  
sensor  
output  
voltage



**Figure 3-**  
Bar MAP  
sensor  
output  
voltage.







**Figure** Potentiometer functionality for closed and open throttle conditions.

**1.1.1.4. TPS Functionality and Wiring**

The TPS allows the **TECs** to provide fuel enrichments for various throttle movement situations, like an accelerator pump on a carburetor. For high rpm, closed throttle situations, (like deceleration or engine braking), it can be used to turn off the fuel flow completely. The TPS is also used to detect closed throttle for the activation of the Idle Air Control parameter. .

Many different TPS's have been used by OEM's in the past few decades. The most common types are driven directly on the throttle shaft by either a dowel pin going through the shaft of a "D" shaped throttle shaft. Various TPS styles are available from Electromotive, as pictured below.



Arm-Style TPS  
PN 310-71310



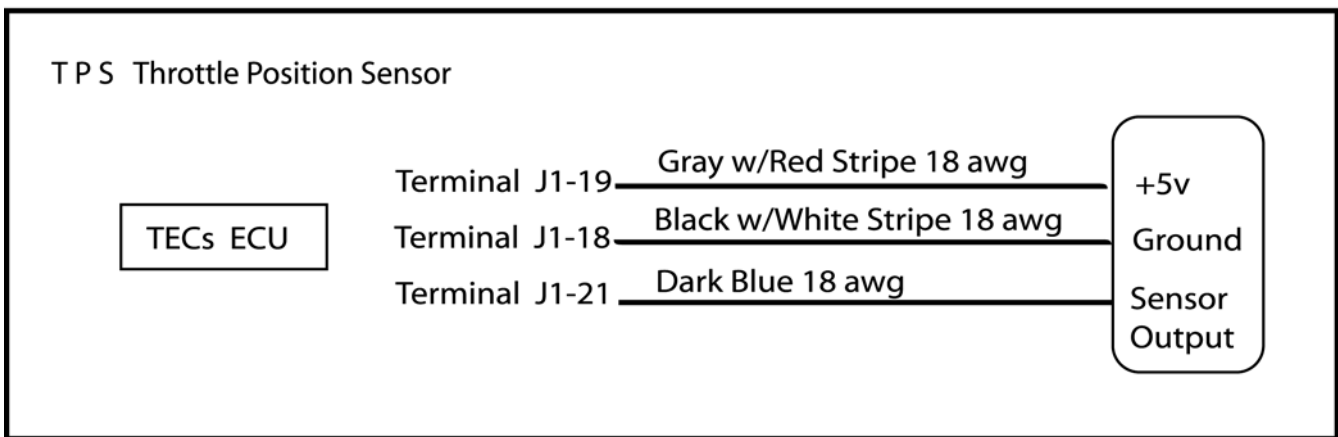
GM Dowel-Pin Style  
PN 310-71320



"D" Shaft TPS  
PN 310-71340



Ford Dowel-Pin Style  
PN 310-71330



The TPS connects to three wires from the **TECs** harness: +5 Volt, Ground, and TPS Signal

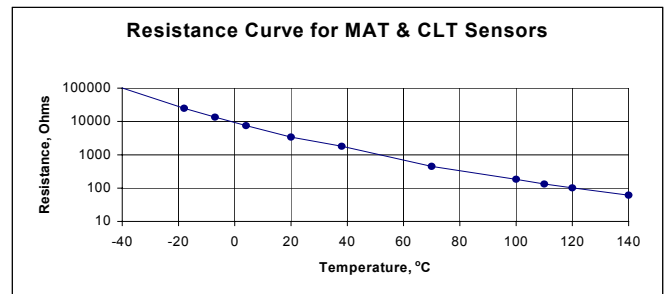
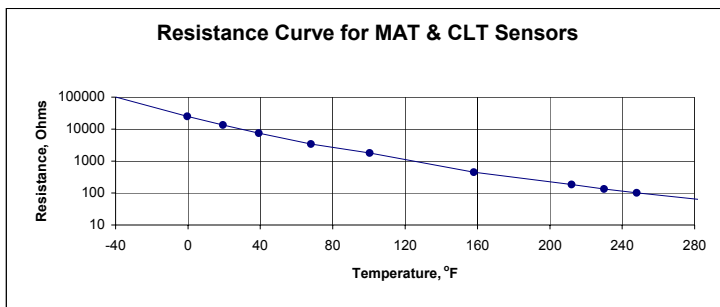
### 4.7.3. Coolant Temperature Sensor

The **TECs** is compatible with negative temperature coefficient (NTC) thermister-type coolant temperature sensors. This type of sensor has two terminals, and the resistance between the two terminals changes as a function of temperature (see **Figure**). The coolant (CLT) sensor provides variable fuel enrichment as a function of engine temperature. The **TECs** is set up to use the GM-style coolant temperature sensors. These sensors are sold by Electromotive under part number 305-71210. They are threaded for a 3/8" NPT hole.

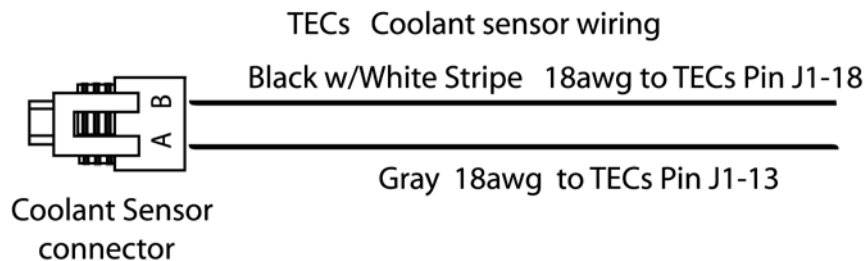


**Liquid-cooled** engines should have the CLT sensor installed somewhere in the coolant passages. Ideally, it should be installed toward the outlet of the engine (or the entry of the radiator) so that the highest temperature reading will be seen.

For **air-cooled** engines, there are a few options for obtaining a usable engine temperature. The first option is to use the factory cylinder temperature sensor, which is often found on air-cooled Porsche applications. The second option is to use the engine oil temperature instead of the coolant temperature. Beware of choosing this method, since air cooled engines often have a very large oil capacity that takes much longer to heat up than the cylinders themselves. A third option would be to use a *manifold air temperature* sensor in a sheet metal "stove" on one of the cylinders.



**Graphs:** Sensor resistance vs. temperature for CLT and MAT sensor.



**Figure:** Coolant temperature sensor wiring.

Wiring the Coolant temperature sensor is straightforward. . Since the sensor is just a resistor, wires "A" and "B" can be switched with no adverse results.

To test for faulty coolant temperature sensors, simply measure the resistance across terminals A and B with an ohmmeter. Match the resistance of the sensor to the operating temperature using **Table G.3.1**. As a guideline, use the following specs:

Cold engine (70F, 20C):      ~3300Ω

Hot Engine (180F, 80C): ~350Ω

**Table G.3.3:** CLT and MAT sensor resistance

| Temp, °C | Temp, °F | Resistance, ohms |
|----------|----------|------------------|
| -40      | -40      | 100700           |
| -18      | 0        | 25000            |
| -7       | 19       | 13500            |
| 4        | 39       | 7500             |
| 20       | 68       | 3400             |
| 38       | 100      | 1800             |
| 70       | 158      | 450              |
| 100      | 212      | 185              |
| 110      | 230      | 133              |
| 120      | 248      | 102              |
| 140      | 284      | 62               |

#### 4.7.4. Manifold Air Temperature Sensor

Like the Coolant Temperature Sensor, the Manifold Air Temperature (MAT) Sensor is an NTC thermister. The MAT sensor allows fuel enrichments for varying inlet air temperatures. This is useful because cold air is denser than warm air, and as a result, cold air needs more fuel. The **TECs** is set up to use the GM-style MAT sensors. These sensors are sold by Electromotive under part number 305-71220. They are threaded for a 3/8" NPT hole. Wiring the MAT sensor is very easy. See **Figure** for details.



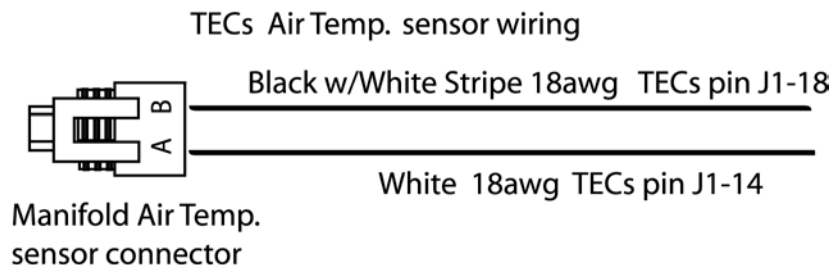
Install the MAT sensor in an area that is representative of the air temperature entering the engine. If it is mounted directly in the intake manifold (particularly in aluminum and iron manifolds), it may be getting a slightly warmer reading than the actual air temperature due to the conduction of heat through the manifold and the radiation of heat onto the sensor tip. It is sometimes better to install the sensor upstream a bit, particularly if the air intake (or filter box) is made of a material that does not conduct heat very well (like plastic). This will give the MAT sensor a more appropriate reading for intake air temperature.

The MAT sensor resistance curve is identical to that of the CLT sensor. See **Figure and Table** for details. The sensor resistance test can be done the same way as well:

#### Resistance for MAT Sensor:

70°F (20°C): ~3300Ω

180°F (80°C): ~350Ω



**Figure:** Manifold air temperature sensor wiring.

## 4.7.5. Exhaust Gas Oxygen Sensor

The Exhaust Gas Oxygen (EGO) sensor is designed to measure the oxygen content of the combustion products. In measuring this value, an estimate of an engine's air-to-fuel ratio (AFR) can be made.

### 1.1.1.5. Mounting the Sensor

The EGO sensor should be mounted in the exhaust stream close to the engine. It should not be mounted in the header pipe for only one cylinder. Instead, it should be mounted after the collector. Failure to mount the EGO sensor close to the engine will result in poor performance due to under-heating the sensor. The EGO sensor needs plenty of heat to operate properly. Mild steel threaded bungs for the EGO sensor are available from Electromotive under PN 315-72111.



When installing the sensor, take care not to run the wires on the exhaust. This will obviously melt the wires once exhaust temperatures rise.

### 1.1.1.6. Wiring the Sensor

Virtually all 4-wire EGO sensors on the market are compatible with the **TECs**. Most universal EGO sensors available from the auto parts store have a color code as follows:

|        |               |
|--------|---------------|
| Black: | EGO +         |
| Gray:  | EGO -         |
| White: | Heater + or - |
| White: | Heater - or + |

Note that the heater polarity is not important, it only needs opposite voltages on the two wires.

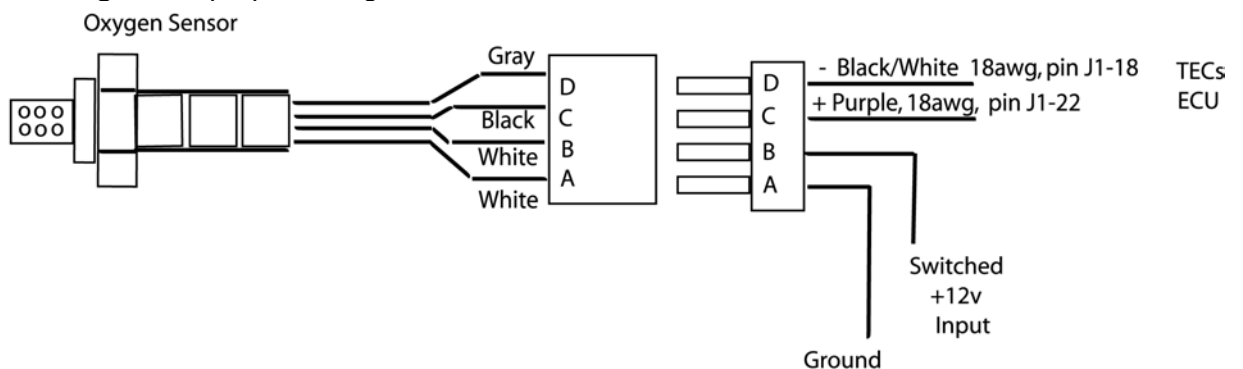
**DO NOT ATTEMPT TO RUN THE EGO HEATER WITH THE +5V LINE IN THE TECs HARNESS!!**

Electromotive's EGO sensors also follow this color code, and are mated to a 4-position female weather-pack connector in the following pin out:

Gray: Pin D    Black : Pin C    White : Pin B    White : Pin A

The heater circuitry allows the EGO sensor to warm up quickly. It also keeps the EGO as warm as possible during idling conditions, where unheated EGO sensors (1-wire style) often cool down significantly. The positive wire for the heater can be spliced to the Fuel Pump output on the **TECs** Power Harness (PN 070-40000). This is the 16awg light green wire. This is NOT the same as the Fuel Pump Relay Ground output of the **TECs**, which is a 20awg light green wire from pin G17.

If the Power Harness for the **TECs** is not being used for the EGO heater element, the EGO heater should be wired to a switched voltage source. If it is wired to a full-time voltage source, it will drain the battery in short order! See **Figure** for proper wiring.



**Figure:** Wiring details for Electromotive's EGO sensor (PN 315-72120).

### 1.1.1.7. A Note on One-Wire EGO Sensors

One Wire EGO sensors were used a number of years ago on early fuel-injected vehicles (and some carbureted engines). These EGO's output the same voltage curve as any standard 4-wire sensor, but do not have a built-in heater or ground reference. Wire the sensor as follows: Connect the wire from the EGO sensor to the EGO+ line on the **TECs** (this is the Purple 20awg wire in the **TECs** Harness).

Connect the EGO- line on the **TECs** to the Sensor Ground line (this is black w/ white stripe 18awg wire.

One-wire sensors are typically not as accurate as 4-wire sensors, since they have no built-in heater element. Instead they must rely on exhaust system heat entirely. Unless the EGO sensor is mounted very close to the engine in a cast iron manifold, 1-wire sensors should not be used.

## 4.7.6. Wideband O2 Sensor Installation Instructions

The **TECs** supports an input from most wideband sensor controllers. The wideband controller must have an analog 5-volt output signal. A typical configuration is shown in the Figure.

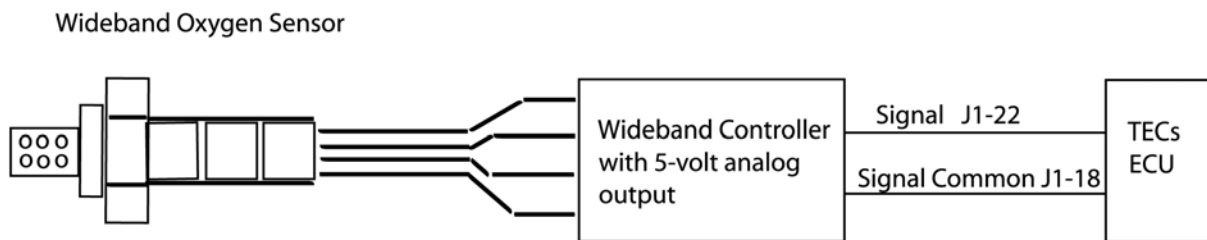


Figure: Typical Wideband Configuration

The installation of the oxygen sensor and controller should follow the wideband controller manufacturer's instructions. The analog 5-volt output signal connects to the O2 sensor (+) (purple wire) on the **TECs**. The **TECs** sensor ground must also connect to wideband controller's ground.

\*Note: Some wideband control units have a sensor ground and a ground for the heater. Other units have only one ground. You should connect the sensor ground to the black/white wire. If there is only one ground or the controller manufacturer recommends grounding the unit directly to the battery, follow the manufacturer's installation instructions.

## 4.7.7. Knock Sensor

To compensate for poor fuel quality and other adverse engine operating conditions, the **TECs** has the ability to retard timing based on detonation. To perform this task, it uses a knock sensor to sense when the engine is experiencing spark knock. The **TECs** uses any 1-wire *FREQUENCY-BASED* knock sensor input. Electromotive stocks a GM 1-wire knock sensor under PN 305-71410. See **Figure** for wiring details.



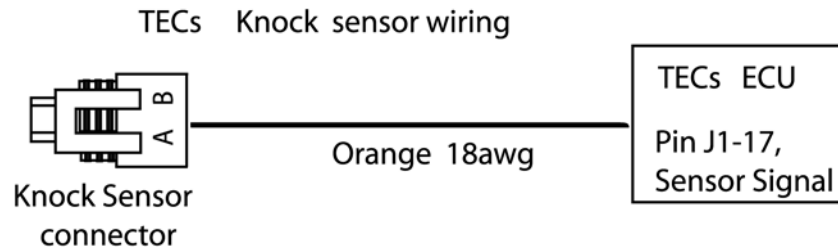


Fig: Knock sensor wiring.

## 4.8. General Purpose Inputs (GPI's) and Outputs (GPO's)

The General Purpose Inputs (GPI's) as well as the General Purpose Outputs (GPO's) will be referred to as **GP I/O's**, they are configurable for many different input or output functions. There are **two** dedicated GPO channels (**#3 and 4**) – (**output only**). The remaining three channels (**1,2 and 5**), can be configured to be either Input or Output.

A few facts that should be remembered when using the GP I/O's :

All the GPO's, regardless of their function, are pull-to-ground when they are activated. That is, they create a connection to ground when turned on.

A MAXIMUM of 1 amp per GPO channel may be run on the TECs.

It is HIGHLY recommended to use a relay on the GPO channels, regardless of amperage draw. Only the FULL TABLE functions require NO RELAY or the use of a solid-state relay. A standard relay will not switch on and off fast enough when using frequency based functions.

An analog input is defined as a 0-5 volt signal. TPS, MAP, and EGO sensors are good examples of analog output sensors. A speed input is defined as a frequency signal. When using a magnetic sensor as a speed sensor, its output will be an AC sine wave. When using a Hall effect sensor, the output will be a 0-5 volt square wave.

One of the most useful functions of the GP I/O's is trimming. Using a simple potentiometer referenced to +5 volts and ground, it is possible to configure the inputs to trim the fuel and spark curves based on the potentiometer knob position. These functions are quite easily configured in the Wintec software.

### 4.8.1. Available General Purpose Input (GPI) Functions:

**Fuel Trim:** Trims the fuel curve by a set amount through the use of a potentiometer. See **Figure** for wiring diagram.

**Ignition Advance Trim:** Trims the ignition advance angle by a set amount through the use of a potentiometer. See **Figure** for wiring diagram.

**GPO Trim #1 and #2:** These functions allow the user to add or subtract up to 50 percent Duty Cycle from the values established in the GPO table specified by the trim number. GPO Trim #1 only effects table 1, GPO Trim #2 only affects table 2.

**A/C Idle Speed Increase:** On **TECs** installations with an idle air control motor, this feature allows the idle speed to be increased when the air conditioner is turned on. See **Figures** for recommended wiring.

**Valet Switch:** When a speed input is used, the valet switch allows the user to set a speed limit on the vehicle. The rev limiter will be activated when the desired speed is reached. See **Figure** for wiring diagram.

**Nitrous Retard:** Provides a set amount of ignition timing retard when nitrous is activated. When used with the Electromotive 4-stage timing retard module, the NOS Retard should be set to  $-30^{\circ}$  (consult the 4-Stage Nitrous Retard Instructions for wiring). When used with a potentiometer, the timing will be retarded linearly from 0 to 30 degrees when a 0 to +5 volt signal is placed on a GP I/O input (channels 2-9).

**Speed Input:** Only available on GP I/O channel 5, the speed input allows the input of a frequency-based signal. Many late-model vehicles use electric speedometers that use either Hall effect or reductor triggering mechanisms. These are both compatible with the **TECs** speed input. Depending on the location of the speed input trigger wheel, you must configure the software to calibrate the speed input signal to the actual vehicle speed. .

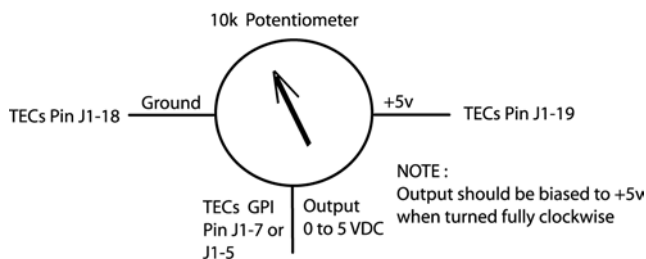
**Timed Advance:** When voltage (either 12v or 5v) is applied to the chosen GP I/O channel this function allows the user to add or subtract up to 30 degrees of timing for up to 2 secs. in .05 sec. increments. Timing will ramp up (advance) in the time specified (up to 2 seconds in .05 sec. increments) or down (retard) when the channel is switched on. Switching the channel off will ramp the timing back to the values in the Ignition Advance Table, the ramp back will happen in the specified time programmed by the user within the software.

**Datalog Enable:** Allows the use of on board data logging function. Options are RPM to begin data logging and Frequency (5, 10, 20 Hz) sampling rate. Wires the same as any input that is switched, such as the Valet Rev Limiter.

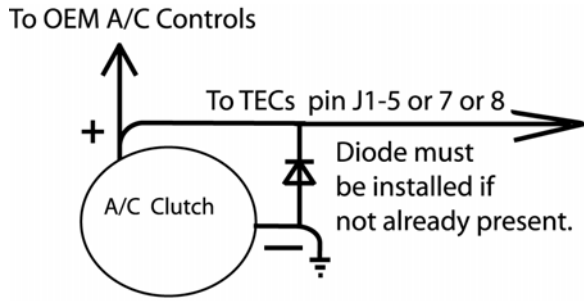
**Voltage Input:** No options, it just gives you a recordable voltage from 0 – 5 volts.

**Timed Ignition Cut:** option for shifting requires minimum RPM and minimum MAP value, amount of time for ignition cut in milliseconds, amount of time before ignition can be cut again. Finally, there is an option to pull to 12v (activate high) or pull to 0v (activate low). Additionally, the line must be released before the channel can be activated again.

## 4.8.2. Wiring the GPI's



Potentiometer wiring for Fuel, Ignition and GPI Trim Inputs



Alternate air conditioner idle speed increase wiring. Note that the A/C clutch solenoid polarity MUST be known for this method.

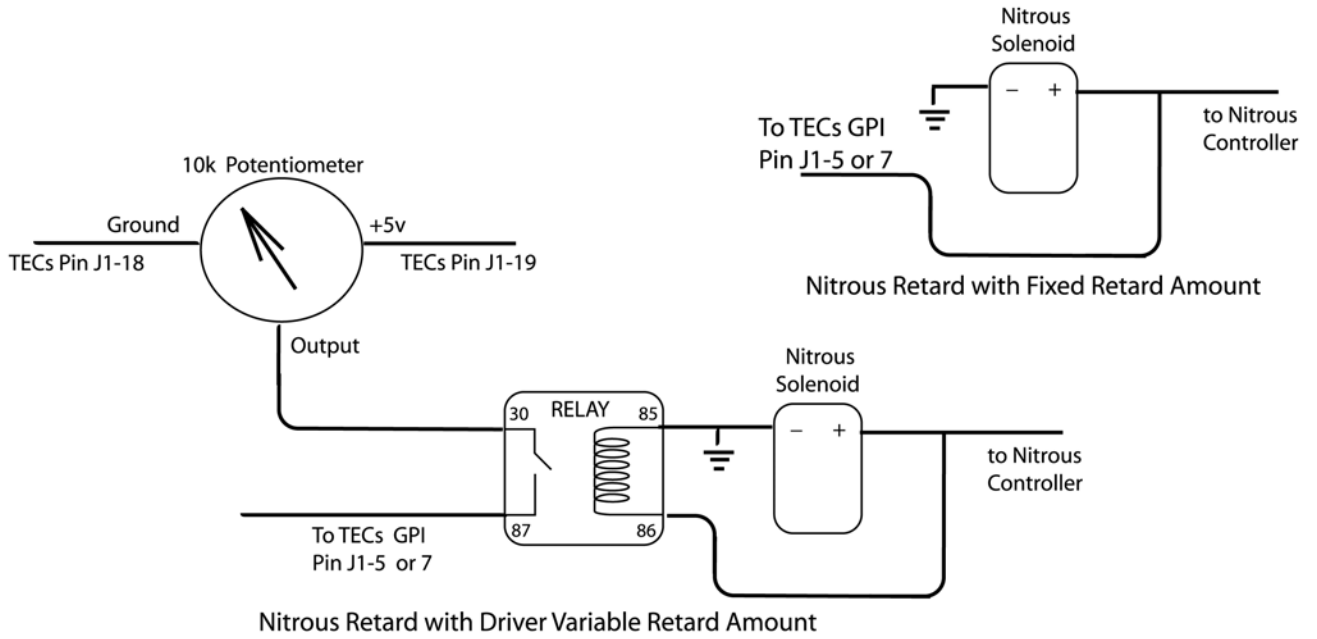


Fig. Nitrous timing retard wiring.

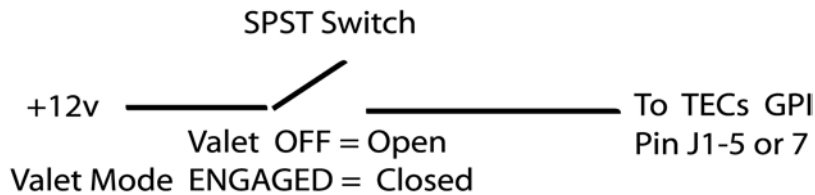
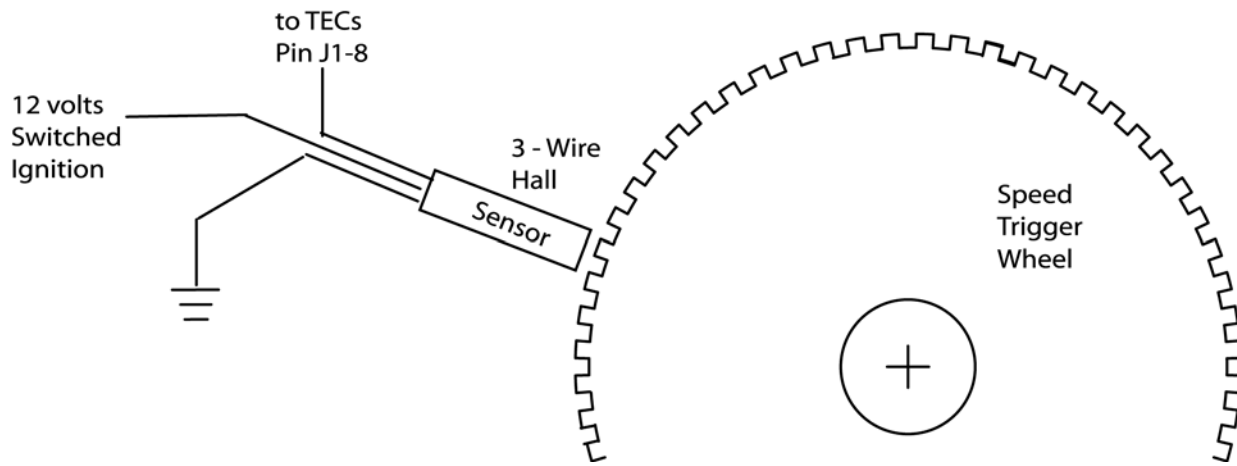


Fig. Valet mode on/off wiring.





**Figure:** Typical speed sensor wiring

### 4.8.3. GP I/O Wiring Harness Layout

|          |          |                              |
|----------|----------|------------------------------|
| GP I/O 1 | Pin J1-5 | White w/ Black Stripe, 18awg |
| GP I/O 2 | Pin J1-7 | White w/Red Stripe, 18awg    |
| GP O-3   | Pin J1-4 | Yellow w/Red Stripe, 18awg   |
| GP O-4   | Pin J1-1 | Yellow w/Blue Stripe, 18awg  |
| GP I/O-5 | Pin J1-8 | White w/Green Stripe, 18awg  |

### 4.8.4. General Purpose Output (GPO) functions

Some of the most versatile functions of the **TECs** computer are its GPO's. These outputs can control virtually any electronics device that is associated with engine operation. Take for example a simple electric radiator fan. Instead of retrofitting a thermo-switch mounted somewhere near the radiator's air stream to turn the fan on and off, you can simply use one channel of the **TECs's** GPO function. To accomplish this task, you would first select the **Radiator Fan** option from the GPO menu for the given channel. Then, you would input the temperature at which the fan should turn on, and the temperature at which it should turn off. The temperature readings are all obtained from the Coolant Temperature Sensor (CLT), so they are much more accurate and reliable than an external thermo-switch. The output of the GPO is a pull-to-ground, so you would run the appropriate GPO wire for the channel you defined as "Radiator Fan" to a standard 4-position automotive relay (pin 85 on the relay). The opposite side of the relay (pin 86) would be wired to +12 volts, and the relay would be switching the power (or the ground) to the fan with pins 30 and 87.

A few facts that must be remembered when using a channel for a GP I/O function :

All the GPO's, regardless of their function, are pull-to-ground outputs when they are activated. That is, they create a connection to ground when turned on.

A MAXIMUM of 1 amp may be drawn from each GP I/O circuit.

It is HIGHLY recommended to use a relay on the output of the GPO channels, regardless of amperage draw.

## 4.8.5. Available GPO Functions

**Radiator Fan:** See previous paragraph for functionality. See **Figure** for wiring diagram.

**Shift Light:** Turns on a shift light (or any other rpm-activated object) at a user-definable RPM. See **Figure** for wiring diagram.

**Torque Converter Control:** Use this GP I/O to control a lock-up torque converter. You are able to define the MAP and Speed points at which the torque converter clutch is activated. Since there is a multitude of different lock-up transmissions, an electrical schematic is not included for this feature. Consult the shop manual for your application to find the wire that engages the torque converter lock-up. Use a GPO channel to activate the proper wire. A relay should always be used for this function.

**Duty Cycle Table:** This GP I/O uses a 16 x 16 table of MAP reading vs. RPM to allow the input of a duty cycle at each MAP/RPM point. Numbers are interpolated between cells to create a smooth curve. The possibilities of this GP I/O are extensive. Typically, it is used to control an rpm/load-dependent solenoid such as a turbo waste gate. You can select table 1 or 2.

**A/C Control:** This feature turns the air conditioner clutch off when the engine is above specific RPM and MAP values. See **Figure** for wiring diagram.

**Auxiliary Fuel Pump:** This GP I/O turns on an auxiliary fuel pump at a desired RPM and MAP value. See **Figure** for wiring diagram.

The **Intake Runner** and **Nitrous Controls** function in the same manner as the **Auxiliary Fuel Pump Control**. That is, they activate as a function of RPM and MAP value. Note that the Nitrous Control should not be used to turn on the nitrous directly. Instead, it should be thought of as a nitrous enable. This essentially replaces the wide-open-throttle switch. Use **Figure** for similar wiring.

**Custom (and) / Custom (or):** Custom (and) uses both ranges RPM and MAP values. It requires RPM below which GPO comes on and MAP minimum turn on value. Custom (or) functions only inside either RPM or MAP values set OR both.

## 4.8.6. Wiring the GPO's:

This section covers the wiring that is necessary to use the various GP I/O controls. With one exception (A/C turn-off), the relays depicted in the schematics are all simple automotive 4-position relays. The air conditioner turn-off request needs a 5-position relay. 4-position and 5-position relays are generally rated at 30 or 40 amps, which should be more than adequate for most applications. High quality relays and relay sockets are available from Electromotive under part numbers 340-91200 and 340-91201, respectively. Part number 340-91200 is a 5-position relay, so it can be used for all applications depicted below.

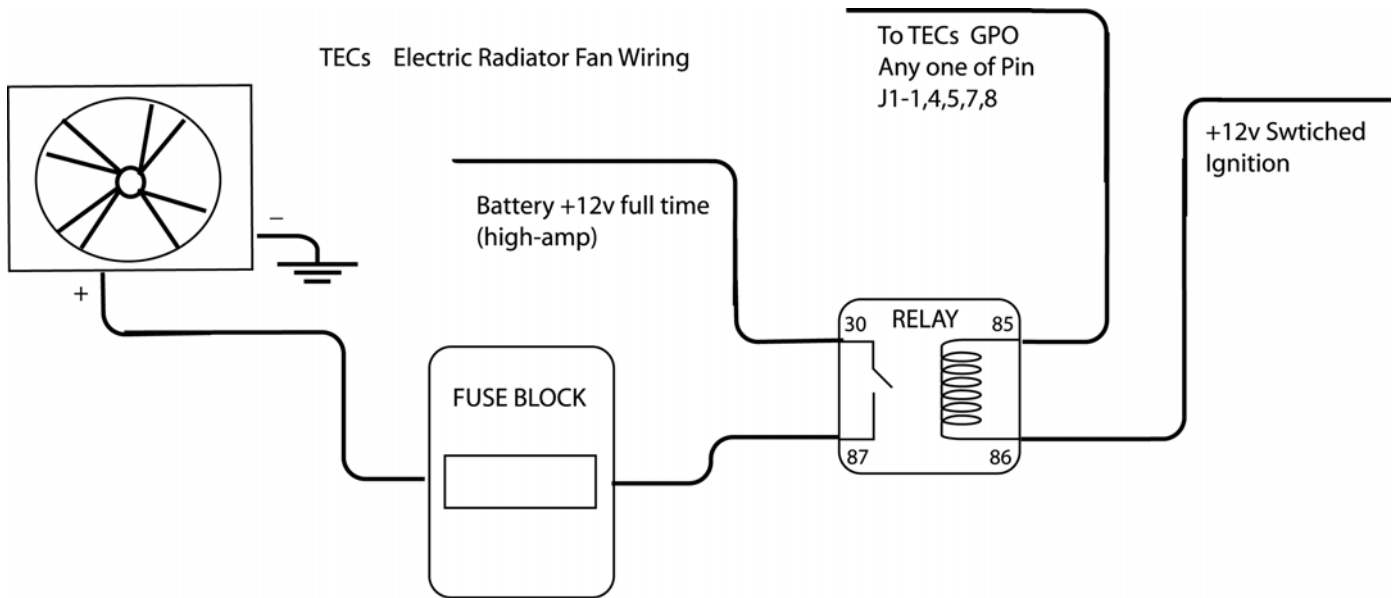


Figure: Electric radiator fan wiring.

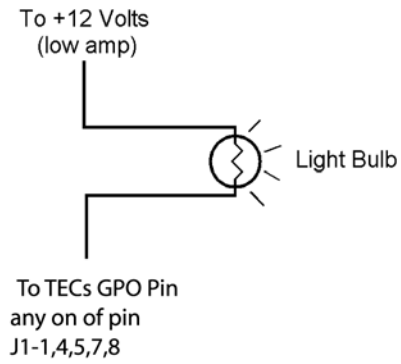
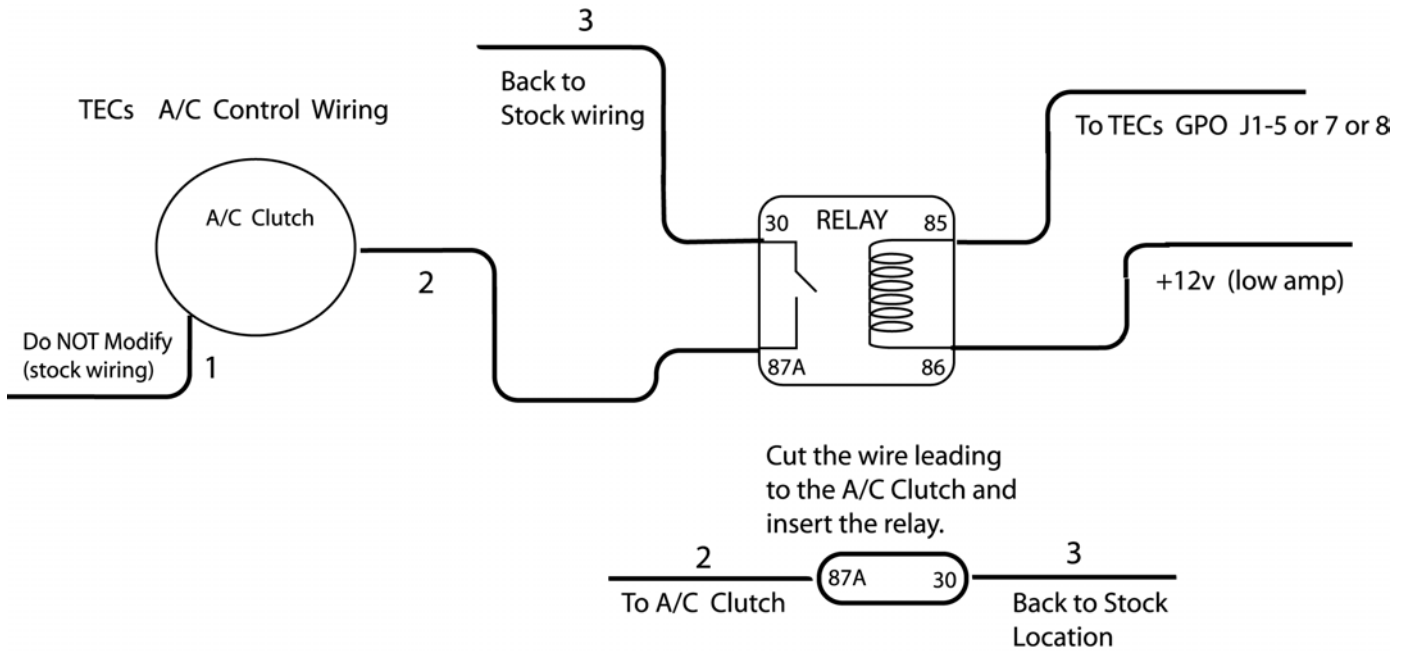
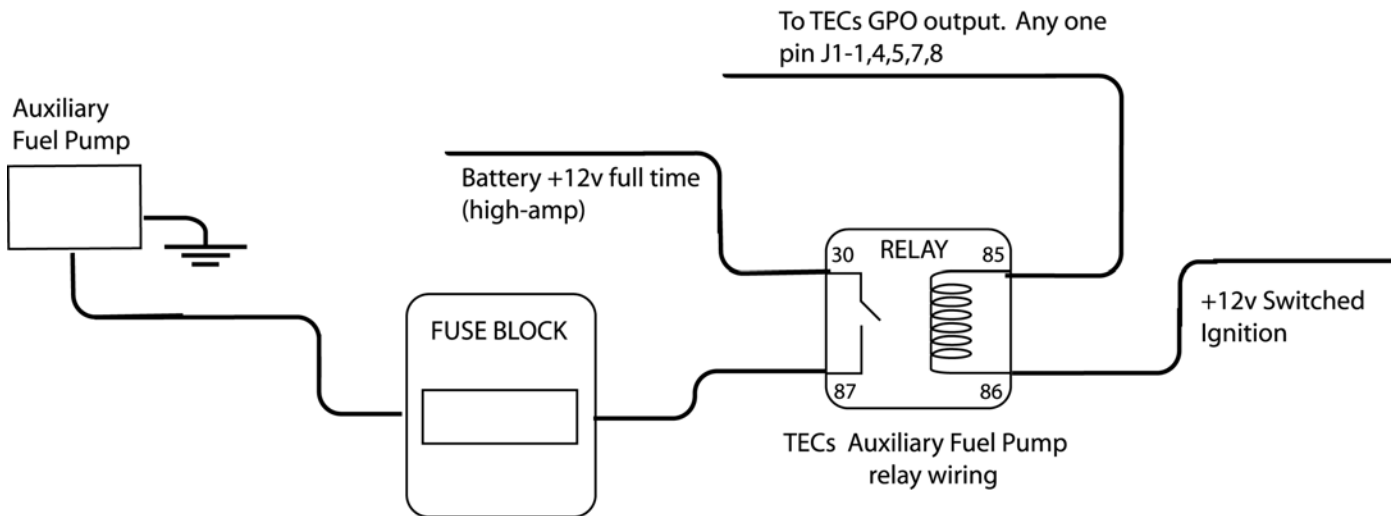


Figure: Shift light wiring.



**Figure:** Air conditioner control wiring. Note that the relay simply splices into either of the two wires on the A/C clutch with terminals 30 and 87a. When activated, the A/C control will break the (normally-closed) connection between 30 and 87a by grounding pin 85.



**Figure H.2.4:** Auxiliary fuel pump wiring

## 5. Diagnostics

The **TECs** has two provisions for diagnostics: an output wire for a “check engine” light and an LED on the ECU. The two outputs perform different tasks that are outlined below.

## 5.1. Trouble Codes from the LED's Mounted on the TECs

The LED's mounted on the **TECs** are used to alert the user's attention to electrical and crank trigger problems. They are also used to show the mode (in terms of the rpm range) in which the **TECs** is operating. Here are the readings from the LED's :

Turn ignition key on (but do not start engine):

Upper LED goes steady green:

Good, the processors are getting power.

Upper LED does not turn on at all:

Either the **TECs** is not receiving +12V power from pin (A), or the ECU has an issue.

Engine cranking (below 400 rpm):

Lower LED changes color from red to green every other revolution:

Good, the crank sensor is working correctly

Lower LED does not change colors:

The crank sensor is not functioning properly (signal is not being picked up).

Engine running (over 400 rpm):

Lower LED is steady green:

Good, the crank trigger is functioning properly.

Lower LED flashes red every so often:

The **TECs** is getting a bad signal from the crank trigger. The engine

Most likely misfires whenever the light flashes red.

Engine is Hitting Rev Limiter:

Lower LED changes color turns orange:

The first or second stage of the rev limiter is occurring.

Lower LED turns red:

The third (and final) rev limiter stage is occurring.

Note:

If a misfire occurs during normal engine operation, but the lower LED on the **TECs** was not observed to momentarily flash red, the crank sensor may be at fault. To test for errors in this situation, turn the engine off without removing power from the **TECs** ECU (this can be accomplished by unplugging the fuel injector harness, or by hitting the letter "K" from the engine monitor screen when using a laptop). If the lower LED is flashing red after the engine is shut off, there was a crank sensor problem at some point during the run.

## 5.2. Trouble Codes from the Check Engine Output

The trouble codes from the check engine output are related to the engine sensors. If the check engine output wire is connected to a light bulb, it will display a sequence of flashes depending on the problem. The diagnostic codes are arranged such that there are two digits for each code. The check engine light will give long duration flashes for the first digit of the code and short duration flashes for the second digit. See **Figure H.2.1** for a graphical representation of the flash sequence. Here are the diagnostic codes (asterisked items are not available with the first software release):

- 12: Crank Trigger Error
- 13: Cam Trigger Error
- 14: ECU Internal Failure\*
- 21: Throttle Position Sensor High
- 22: Throttle Position Sensor Low
- 23: Manifold Air Pressure Sensor High
- 24: Manifold Air Pressure Sensor Low
- 25: Coolant Temperature Sensor High
- 26: Coolant Temperature Sensor Low
- 31: Manifold Air Temperature Sensor High

- 32: Manifold Air Temperature Sensor Low
- 33: High Battery Voltage
- 34: Low Battery Voltage
- 35: Knock too Long
- 37: Exhaust Gas Oxygen Sensor Lean too Long
- 38: Exhaust Gas Oxygen Sensor Rich too Long\*
- 51: GPO 1 Failure
- 52: GP I/O 2Failure
- 53: GP I/O 5Failure

### 5.3. Trouble Code Descriptions

**Code 12 – Crank Trigger Error:** This code will register when the ECU has detected a problem with the crank trigger signal. If any of the failure scenarios have been detected in the section above on the crank sensor LED diagnostic, this code will be displayed

**Code 13 – Cam Trigger Error:** The ECU is not getting an appropriate signal from the cam sensor. A broken cam trigger wheel or a bad cam sensor could cause this error. This code will only be displayed on sequential applications.

**Code 14 – ECU Internal Failure:** This code is displayed when there has been a substantial failure inside the ECU. Call Technical support for further information.

Codes 21 & 22 – TPS High/Low: See above description.

**Codes 23 & 24 – Manifold Air Pressure High/Low:** These codes are set when the MAP sensor has gone outside its specified range. This can be useful for a boosted application to trigger a check engine signal when an over-boost situation has occurred. Alternately, it can be used to detect a short in the wires. When this code is displayed, the **TECs** will be using the MAP Failure Default value for MAP calculations. As such, there will be no load input to the **TECs's** ECU, and the computer will enter into a "limp-home" mode.

**Codes 25 & 26 – Coolant Temperature Sensor High/Low:** Once again, these codes are set when the coolant temperature reading is outside its specified range. Use this light to warn of coolant temperatures that are too high. When this code is displayed, the **TECs** will be using the CLT Failure Default value for coolant-based calculations. As such, there will be no engine temperature input to the **TECs's** ECU.

**Codes 31 & 32 – Manifold Air Temperature Sensor High/Low:** Works identically to codes 25 & 26, except for the MAT sensor.

**Code 33 – Battery Voltage too High:** The battery voltage has exceeded 17 Volts. A bad voltage regulator on the alternator can cause this.

**Code 34 – Battery Voltage too Low:** The battery voltage has gone below 7.5 Volts. Check the state of charge on the battery. Also check all power connections.

**Code 35 – Knock too Long:** The ECU has recorded a level of engine spark knock (from the knock sensor) for a duration that exceeds what was established in the software. This code is indicative of either poor fuel quality, or extreme engine temperatures leading to spark knock. Some tuning will be required for the knock sensor trouble codes, since all engines make noises that will trigger the knock sensor, but which are not caused by spark knock.

**Code 37 – EGO Lean too Long:** This code is set when the oxygen sensor reading is lean for a prolonged period of time. Make sure the sensor has not come unplugged.

**Code 38 – EGO Rich too Long:** This code is set when the oxygen sensor reading is rich for a prolonged period of time. Make sure the sensor is not shorted to +12 Volts.

**Codes 41&42, 43&44, 45&46, 47&48** all function like Codes 23&24, except they are for the Analog to Digital Inputs.

**Codes 51-54 – GP I/O 1-9 Failure:** These codes are set when the GP I/O input/outputs have been shorted to voltage or have been over-drawn (too much current). Make sure that the total circuit draw for GP I/O's 1-9 is less than 10 amps (1 amp per channel).

**Code 55 – Fuel Pump Output Failure:** The fuel pump output has seen an over-current situation, or is shorted to power.

**Code 56 – Check Engine Output Failure:** The check engine output has seen an over-current situation, or is shorted to power. The code can only be seen with a laptop, since the check engine light is likely at fault.

### 5.3.1. Using the Trouble Codes

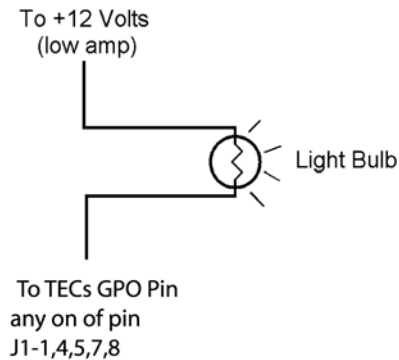
The trouble codes are displayed for a sensor when the maximum or minimum value for a sensor has been exceeded. Since the maximum and minimum points are user-definable in the Wintec software, a failure code does not necessarily indicate a failed sensor (i.e. the failure parameters may be set incorrectly). As an example, let's look at the Throttle Position Sensor Parameters. Before the parameters can be entered into the software, it is necessary to know the TPS voltage at both fully closed and wide-open throttle. This can be observed in the monitor screen by opening and closing the throttle (without the engine running). If the closed throttle voltage was 1.0 volt and the wide-open throttle voltage was 4.6 volts, the TPS parameters should be set as follows:

TPS Fully Closed Throttle Voltage: 1.1 Volts  
TPS Wide Open Throttle Voltage: 4.5 Volts  
TPS High Voltage Failure (0-5V): 4.8 Volts  
TPS Low Voltage Failure (0-5 V): 0.8 Volts  
TPS Failure Default Value (0-5V): 1.5 Volts

As can be seen, the **Fully Closed Throttle Voltage** setting is actually a bit above the actual closed throttle voltage (1.1V > 1.0V). This is done because the Idle Speed Control will only start working when the TPS reading is below the **Fully Closed Throttle Voltage** setting. The **Low Voltage Failure** setting is made a few tenths of a volt lower than the actual closed throttle voltage (1.0V > 0.8V). This is done to display [code 22](#) for throttle position sensors that have either rotated in their mount or have failed completely by outputting a lower-than-expected voltage. Likewise, the **High Voltage Failure** setting is made a few tenths of a volt higher than the observed wide-open throttle voltage. This will allow [code 21](#) to be displayed in the event of a high voltage failure. The **Failure Default Value** is the voltage that the **TECs** will use for its TPS-based calculations when the TPS sensor has failed. Since this is a fixed value, there will be no TPS-based acceleration enrichments when the TPS has failed. However, the Failure Default Value is useful for applications using the TPS-MAP Blend feature because it defines a fixed amount of TPS to blend with the MAP sensor during a TPS failure.

### 5.3.2. Wiring the Check Engine Light

The check engine light output utilizes one of the GPO channels. A light bulb of 3 Watts or less should be used. See [Figure I.2.1](#) for wiring instructions.



**Figure I.2.1:** Wiring diagram for the check engine output.

## 6. TECs ECU Specifications

### 6.1. OUTPUTS

#### 6.1.1. Fuel Injector Drivers

4 x saturated switch injector drivers  
 2 injectors maximum per channel  
 12-ohm high impedance injectors can be driven

#### 6.1.2. Coil Outputs

2 x 9amp direct-fire coil drivers  
 Feedback charging loop for ideal cylinder-to-cylinder consistency  
 No "ignition modules" or "CD" boxes needed

#### 6.1.3. Idle Air Control (IAC) Motor

2-wire IAC valve control  
 Adjustable idle speed increase for cold starts  
 Adjusts idle speed in response to engine load (i.e. A/C activation)

#### 6.1.4. General Purpose Inputs or Outputs (GP I / O's)

5 channel low-amp pull-to-ground I/O's  
 Channels have pulse-width capability (up to 2 at a time)  
 Channels 1-5: on/off activation for fan relays, torque converters, waste gates, etc.  
 1 amp max per GP I/O channel

#### 6.1.5. Fuel Pump Control

Low current pull-to-ground output for activation of fuel pump relay  
 Configurable for fuel system priming

#### 6.1.6. Tachometer Output

Drives modern 0-12 volt tachometers  
 Amplifier available for high voltage triggered tachometers

#### 6.1.7. Check Engine Light Output

Pull-to-ground output for instrument panel light (1 amp max current draw)



## 6.1.8. ECU Diagnostic LED

Warns of crank trigger problems  
Multi-code diagnostics

## 6.2. INPUTS

### 6.2.1. General Purpose Inputs or Outputs (GP I / O's)

5 channels low-amp pull-to-ground I/O's  
Channel 1 may be used for speed inputs (magnetic, optical, and hall effect sensors are supported)  
Provides fuel and ignition trims, valet switch, NOS retard, and more

### 6.2.2. Engine Sensor Inputs

Crank Sensor  
2-wire magnetic sensor (compatible w/ some OEM's)  
Uses Electromotive-spec 60(-2) tooth crank trigger  
Ultra-high resolution engine position input  
Cam Sensor  
Necessary for full-sequential applications  
Once-per-cam-revolution pulse  
Manifold Air Pressure (MAP) Sensor  
1 Bar: 0-104kPa absolute  
30"Hg – 0"Hg (naturally aspirated)  
2 Bar: 0-206kPa absolute (up to 1 Bar Boost)  
30"Hg – 15psi (up to 15 psi Boost)  
3 Bar: 0-313kPa absolute (up to 2 Bar Boost)  
30"Hg – 30psi (up to 30psi Boost)  
Throttle Position Sensor (TPS)  
Uses throttle shaft-mounted rotary potentiometer  
Compatible with most OEM 3-wire setups  
Coolant Temperature Sensor (CLT)  
Uses NTC thermister coolant sensor (2-wire)  
Manifold Air Temperature Sensor (MAT)  
Uses NTC thermister manifold temperature sensor (2-wire)  
Knock Sensor (KNK)  
Provides ability to detect pre-ignition  
Compatible with piezo-style knock sensors (1-wire)  
Oxygen Sensor (EGO)  
Compatible with 1-, 3-, and 4-wire oxygen sensors  
Wide Band converter modules (0-5v output)

### 6.2.3. Angle Based Timing Control

Ultra-high resolution triggering  
Engine position known to within 1/8°

### 6.2.4. Feedback Charging Control

Monitors each coil firing event  
Coil current monitoring  
Consistent dwell adjustment  
Full coil charging without overcharging

## **6.3. Tuning Features**

### **6.3.1. Ignition Timing Map**

8 x 8 user definable tables of RPM vs. MAP for ignition advance angle  
65535-point interpolation between data points  
1° adjustment increments  
+/-1/4° spark timing accuracy, worst case

### **6.3.2. Fuel Map**

Two numbers define slope of fuel curve  
8 x 8 tables of RPM vs. MAP for volumetric efficiency corrections  
65535-point interpolation between data points  
1% adjustment increments (up to 0.001 millisecond resolution)

### **6.3.3. Load Sensing – Three Options**

MAP sensor based  
TPS & MAP based (using 'TPS/MAP Blend' feature)  
TPS Based (using 100% TPS/MAP Blend)

### **6.3.4. Rev Limiters**

Progressive “soft” rev limiter (3 stages)  
Fuel injector cutoff  
1000-20000rpm capability for primary rev limiter  
1500-12000rpm capability for auxiliary rev limiter

### **6.3.5. On-Fly Tuning**

Glitch-free, real-time tuning while engine is running  
Full control of all fuel, ignition, and input/output parameters

### **6.3.6. Compensation Features**

Fuel  
Individual cylinder fuel trims  
Oxygen sensor closed loop corrections  
Starting (cranking) enrichments  
Cold start / cold weather enrichments  
Accelerator pump enrichments  
Deceleration fuel cutoff  
Battery voltage correction for injector pulse widths  
Ignition  
Coolant temperature-based advance adjustments  
Manifold air temperature-based advance adjustments  
Smooth idle advance control (integrated w/ IAC settings)

## **6.4. Supported Engine Management Configurations**

### **6.4.1. 4-Stroke**

1-, 2-, 3-, 4-cylinder even-fire engines.  
Full sequential fuel injection  
Phase-sequential  
Waste-spark ignition control for all applications

### **6.4.2. 2-Stroke**

1-, 2- cylinder engines.  
Full sequential fuel injection

Coil-per-plug for all applications

## 6.5. Data logging Features

### 6.5.1. Laptop Data logging

Records to hard drive on laptop

Sampling rate is approximately 50 samples-per-second

Total data logging time is limited only by hard drive space

## 6.6. Physical Dimensions

Length: 3.9"  
Width: 4.6"  
Height: 1.65"  
Weight: 1.55 lbs  
Bolt Hole Pattern: 4.3" x 4.3"

## 6.7. Environmental Considerations

One Sealed 23-Pin AMP Connector for Inputs & Outputs

Sealed High-Amperage Delphi Main Power Connector

Sealed Printed Circuit Board

## 6.8. PC Requirements

### 6.8.1. Computer

IBM-Compatible PC

Pentium-1 233 or better

1024 x 768 monitor resolution (256 colors)

64 Mb of ram

10 MB of free hard drive space

### 6.8.2. Data Drives

CD-ROM for software installation

### 6.8.3. Communications

RS-232 9- or 25-pin D connector

COM 1-99 (software selectable)

## 7. Electromotive Trigger Wheel Availability

Universal 60(-2) Tooth Crank Trigger Wheels – All Have 1" Center Hole (unless noted)

8.25" Outer Diameter PN 230-72682

7.25" Outer Diameter PN 230-72672

6" Outer Diameter PN 230-72660

5" Outer Diameter PN 230-72650

|                              |              |
|------------------------------|--------------|
| 3.5" Outer Diameter          | PN 230-72635 |
| 2.5" OD, 1.5" Center Hole    | PN 230-72625 |
| 2.375" OD, 0.25" center Hole | PN 230-72624 |

Universal 120(-4) Tooth Wheels Cam Trigger Wheels

|                      |              |
|----------------------|--------------|
| 2.75" Outer Diameter | PN 230-72128 |
| 3.25" Outer Diameter | PN 230-72133 |

**Custom Bolt-On Trigger Wheel Kits** – All custom kits include everything necessary to install a trigger setup. Kits with a 220- Part Number reuse the stock sensor and mount in the stock location. Kits with 205- designations use the 3/8" sensors, while 200- kits use the 1/2" sensors.

|  |              |
|--|--------------|
| Chevrolet Small Block – 8" Damper  | PN 200-72808 |
| Chevrolet Small Block – All Other Dampers                                    | PN 200-72707 |
| Chevrolet LT1  | PN 205-72828 |
| Chevrolet Big Block – all Dampers  | PN 200-72820 |
| Ford Small Block – 351W Based Engines  | PN 200-72819 |
| Ford 4.6L & 5.4L SOHC and DOHC   | PN 220-72500 |
| Toyota Supra 3.0L 2JZ-GE & GTE (1993-1998)<br>(includes current Lexus IS300) | PN 220-72301 |
| Eclipse/Talon 2.0L (1 <sup>st</sup> Generation only)                         | PN 200-73002 |
| Honda 'B' Series DOHC VTEC (No P/S or A/C)                                   | PN 200-72410 |
| Dodge Neon (1 <sup>st</sup> generation SOHC & DOHC)                          | PN 200-73001 |
| VW Type 1  | PN 200-72401 |
| Jeep 4.2 Liter   | PN 205-72780 |
| 2 <sup>nd</sup> Generation MR2 Turbo & NA                                    | Coming Soon  |

Please note that most common engines have trigger kits made by our various dealers. Porsche, Mazda, Toyota, Acura/Honda and Subaru applications are currently covered extensively.

## 8. Calibration Software

The **TECs** Calibration Software is called WinTec4 and is available from Electromotive's website. Please refer to the WinTEC4 software guide to learn how to use it and calibrate your system to your specific engine.

The **TECs** is designed to be fully upgradeable with respect to its software and firmware. The software is the operating system that is used to tune the engine. The firmware is the embedded code that is installed in the **TECs's** processors. Small changes in functionality can be covered with software changes. Larger changes in functionality, particularly the addition of new features, generally require a firmware upgrade. Both software and firmware upgrades are available on our website.

### 8.1. Software Coding Information

Electromotive calls its **TECs** Windows software "Wintec 4.X.Y." The "4.X.Y" portion of the Wintec name is the code that is used to tell what the version of software is made for.

The "4" means simply the software version 4 platform.

- The "X" digit states the FIRMWARE version on which the software will function.

The "Y" digit states the latest build SOFTWARE version.

The software version is displayed when the Wintec software is opened on a computer. Software versions are compatible with the firmware version for which they are designed. For example,

A 4.0.3 software version is compatible with a 4.0.0 firmware version.

A 4.1.2 software version is compatible with a 4.1.0 firmware version.

A 4.1.0 software version WILL NOT run with a 4.0.0 firmware version.

Always use the PC SOFTWARE version for which the FIRMWARE is designed. The "X" digit of the PC software must always match the "X" digit of the Firmware!

### 8.2. Firmware Coding Information

The Firmware version is displayed in the Engine Monitor Screen. The firmware code is "4.X.0.T3" The "X" digit must match the "X" digit of the software version (see above). This is the firmware version. Firmware for the **TECs** starts with "WTS02". The next two digits XX are the release version; release changes, new feature additions or some other major change will be signified in this number. The last 3 digits are the build number. Build number YYY indicates bug fixes from one release level to the next. Example: where firmware file number "WTS02xxyyy" XX is the release number, YYY is the build number.

### 8.3. Firmware Upgrade Procedure

Care must be taken when installing different firmware versions on your **TECs** ECU. Follow the steps outlined below:

Download the Firmware upgrade from the Electromotive website.

Install the firmware upgrade on the PC that you will use to tune the engine.

Connect the **TECs** to the PC serial port and power it ON.

1. Startup the Wintec software, it should show in the System console that the unit was found and display the firmware version.

In the main menu bar of the Wintec Software, click on Tools > Options > firmware upgrade. A warning and some instructions will appear. Click OK, and an open dialog will display. Find and select the new ( .em3 ) file you have downloaded.

2. Once the upgrade is complete, cycle the power to the TEC. If the firmware upgrade was successful, both LED's will go GREEN. If the firmware upgrade failed, the top LED will stay RED and the bottom will stay off. If this occurs, start the procedure over at step 5.

The firmware is now upgraded, you can begin/continue tuning.

## 9. TECs Wiring

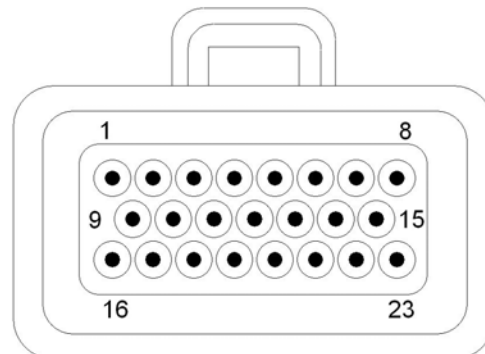
### 9.1. Pinout Information

| Connector Pin | Function | Color                   | Gauge     | Going To |                |
|---------------|----------|-------------------------|-----------|----------|----------------|
| Blue          | 1        | Injector or GPO 4       | Yel/Blue  | 18 TXL   | Load           |
| Blue          | 2        | Coil Shield             | Shield    | 18 TXL   | Ignition Coils |
| Blue          | 3        | Fuel Pump               | Lt. Green | 18 TXL   | Relay          |
| Blue          | 4        | Injector or GPO 3       | Yel/Grn   | 18 TXL   | Load           |
| Blue          | 5        | GPIO1                   | Wht/Blk   | 18 TXL   | Load or Input  |
| Blue          | 6        | Injector 2              | Yel/Red   | 18 TXL   | Load           |
| Blue          | 7        | GPIO2                   | Wht/Red   | 18 TXL   | Load or Input  |
| Blue          | 8        | GPO5/Speed              | Wht/Grn   | 18 TXL   | Load or Input  |
| Blue          | 9        | Coil A                  | Black     | 16 TSP   | Ignition Coils |
| Blue          | 10       | Crank Sensor - & Shield | Blk&Shld  | 22 TSP   | Sensor         |
| Blue          | 11       | Crank Sensor +          | Red       | 22 TSP   | Sensor         |
| Blue          | 12       | CAM Sensor              | Tan       | 18 TXL   | Sensor         |
| Blue          | 13       | Coolant Temp            | Gray      | 18 TXL   | Sensor         |
| Blue          | 14       | Manifold Temp           | White     | 18 TXL   | Sensor         |
| Blue          | 15       | Tach Out                | Brown     | 18 TXL   | Tachometer     |
| Blue          | 16       | Coil B                  | Red       | 16 TSP   | Ignition Coils |
| Blue          | 17       | Knock                   | Orange    | 18 TXL   | Sensor         |
| Blue          | 18       | Sensor Gnd              | Blk/Wht   | 18 TXL   | Various Common |
| Blue          | 19       | +5 Volts                | Gry/Red   | 18 TXL   | Various +5V    |
| Blue          | 20       | Manifold Pressure       | D. Green  | 18 TXL   | Sensor         |
| Blue          | 21       | Throttle Position       | D. Blue   | 18 TXL   | Sensor         |
| Blue          | 22       | EGO +                   | Purple    | 18 TXL   | Sensor         |
| Blue          | 23       | Injector 1              | Yel/Blk   | 18 TXL   | Load           |

Power Leads:

| Connector Pin | Function             | Color | Gauge  |
|---------------|----------------------|-------|--------|
| MP630 B       | Ground               | Black | 10 TXL |
| MP630 A       | Switched Battery 12V | Red   | 12 TXL |

### 9.2. Connector Pin Locations



Wire side of connector





# 9.4. TECs 4 Cylinder Power Wiring

